

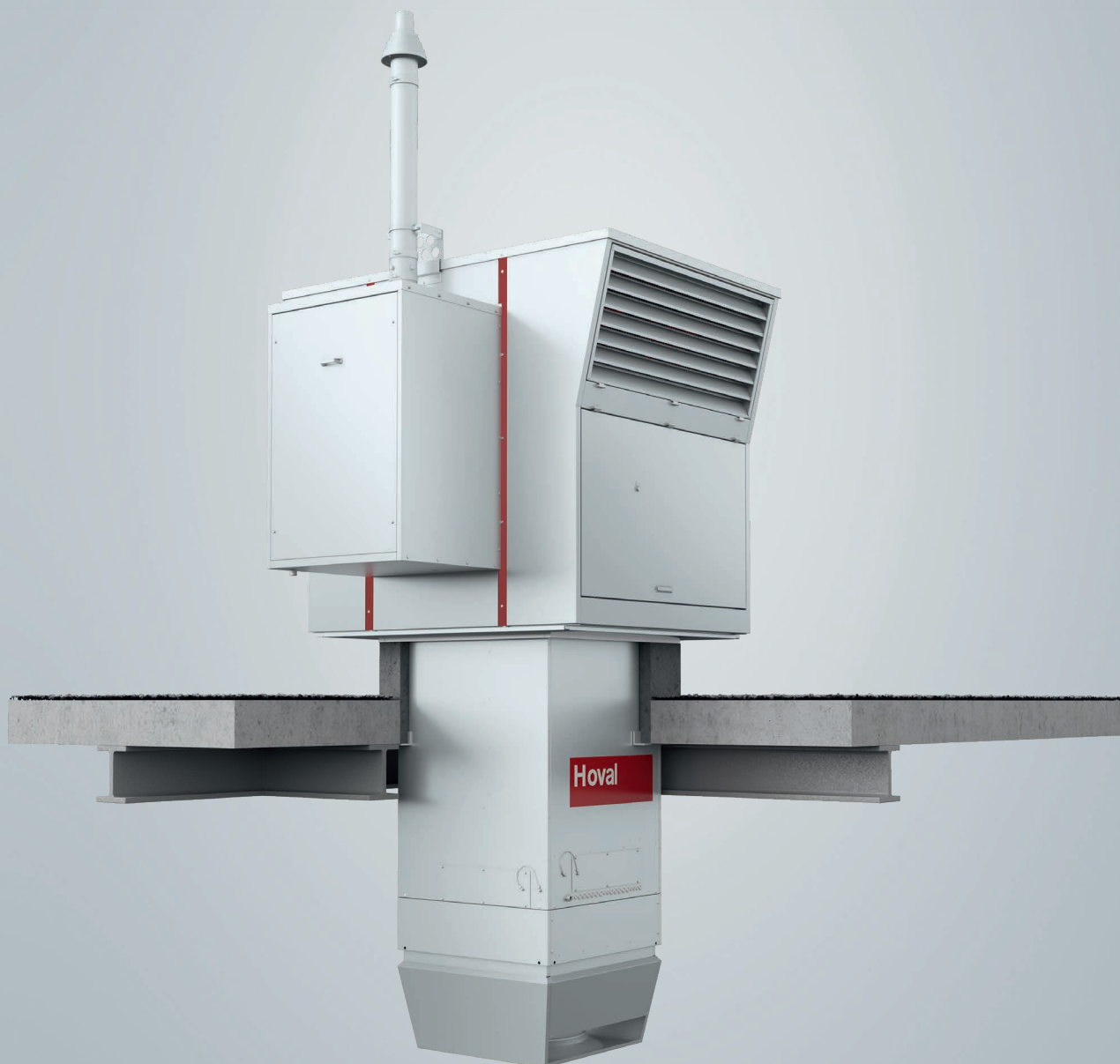





## Hoval RoofVent<sup>®</sup> RG

### Design handbook

Supply and extract air handling units with efficient air distribution  
for heating with decentralised condensing gas boiler



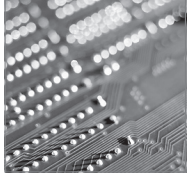

	<p><b>Hoval Indoor Climate Systems</b> 3</p> <p>Efficient. Flexible. Reliable.</p>	<p>A</p>
	<p><b>RoofVent® RG</b> 7</p> <p>Supply and extract air handling unit with efficient air distribution for heating spaces up to 25 m in height with decentralised condensing gas boiler</p>	<p>B</p>
	<p><b>Options</b> 25</p>	<p>C</p>
	<p><b>Transport and installation</b> 31</p>	<p>D</p>
	<p><b>System design</b> 39</p>	<p>E</p>
	<p><b>Control systems</b></p> <p>Hoval TopTronic® C          → see 'Control Systems for Hoval Indoor Climate Systems' manual</p>	<p></p>





## Hoval Indoor Climate Systems

Efficient. Flexible. Reliable.

A





## Efficient. Flexible. Reliable.

Hoval indoor climate systems are decentralised systems for heating, cooling and ventilating halls for industrial, commercial and leisure applications. The systems have a modular structure. One system comprises several ventilation units which are spread around the room. These units are equipped with reversible heat pumps and gas-fired appliances for decentralised heat and cold generation, or they heat and cool with a connection to a central energy supply. Tailored control systems complete the system and ensure the effective combination and optimal use of all resources.

### Diverse range of units ensures flexibility

Different types of ventilation units can be combined to create the perfect system for the project in question:

- RoofVent® supply and extract air handling units
- TopVent® supply air units
- TopVent® recirculation units

The number of supply and extract air handling units depends on how much fresh air is required in order to create a comfortable atmosphere for people in the building. Recirculation units cover additional heat or cool demand as required. A broad range of unit types and sizes with heating and cooling coils in various output levels means that the overall output of the system can be scaled to whatever level is required.

Specially designed unit versions are also available for halls with particularly humid or oily extract air.

Furthermore, there is a range of units available which have been expressly developed for very specific purposes. ProcessVent units, for example, are coupled with extract air purification systems in industrial halls and recover heat from process air.

### Draught-free air distribution

A key feature of Hoval indoor climate units is the patented vortex air distributor, known as the Air-Injector. It is controlled automatically and changes the blowing angle of the air continuously between vertical and horizontal. The highly efficient air supply system has many advantages:

- It provides a high level of comfort during heating and cooling. No draughts develop in the hall.
- The efficient and even air distribution ensures that the indoor climate units cover a large area.
- The Air-Injector keeps the temperature stratification in the room low, thus minimising heat loss through the roof.

### Control with specialist expertise

The TopTronic® C control system, which was specifically developed for Hoval indoor climate systems, regulates the separate units individually and controls them based on zones. This enables optimal adjustment to the local requirements of the different usage areas in the building. The patented control algorithm optimises energy use and ensures maximum comfort and hygiene levels. Clear interfaces make it easy to connect the system to the building management system.

Simpler control systems are also available for units that are only used for supply air or air recirculation.

### Competent and reliable

Hoval will support you and provide expert knowledge throughout all project phases. You can rely on comprehensive technical advice when it comes to planning Hoval indoor climate systems and on the skills of the Hoval technicians during the installation, commissioning and maintenance of the system.

### System with decentralised heat and cold generation with heat pump

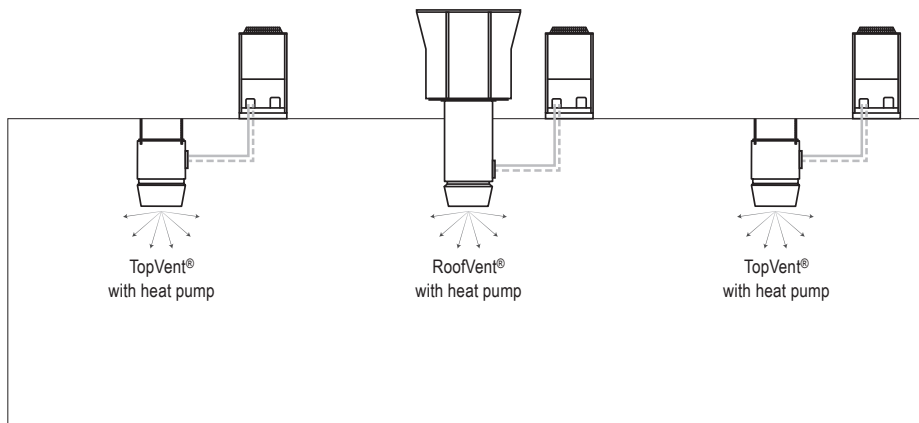

### System with central heat and cold generation

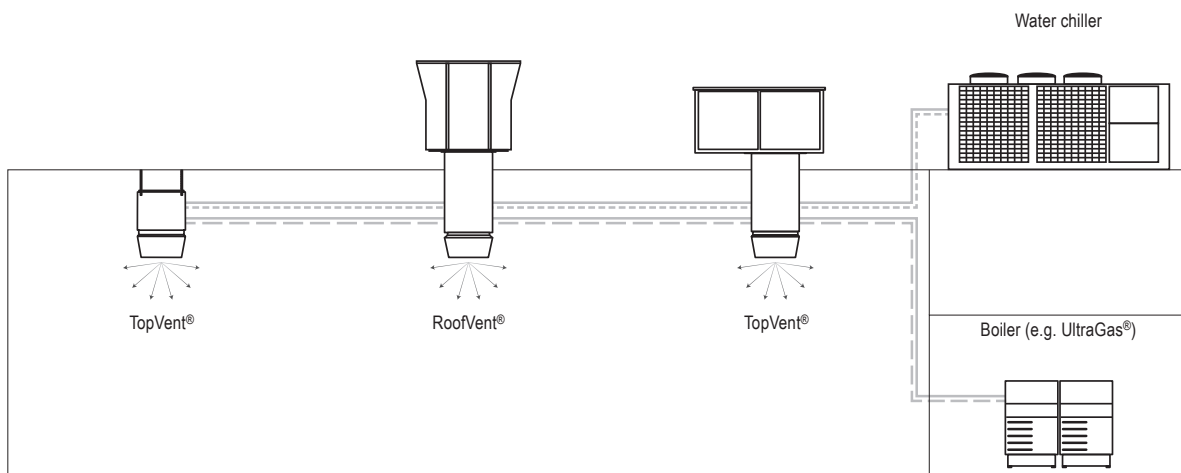

### System with decentralised, gas-fired heat generation

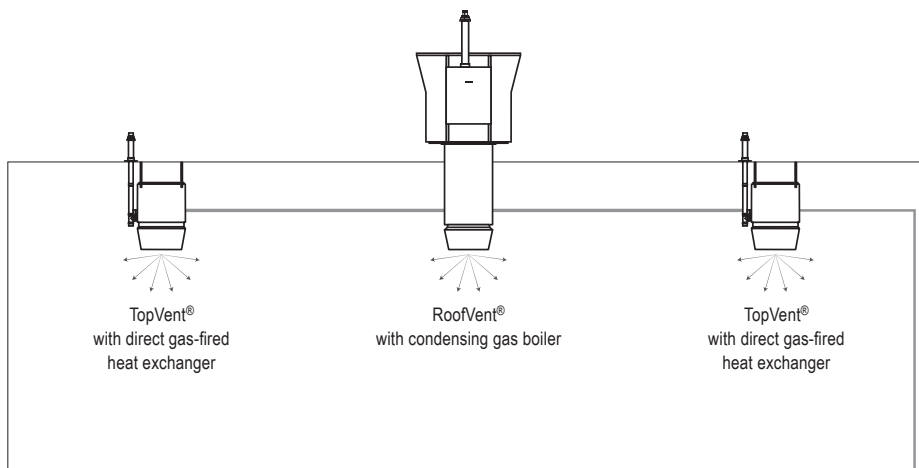







**RoofVent® RG**

Supply and extract air handling unit with efficient air distribution for heating spaces up to 25 m in height with decentralised condensing gas boiler

1 Use . . . . .	8
2 Construction and operation . . . . .	8
3 Technical data . . . . .	15
4 Specification texts . . . . .	20

B

## 1 Use

### 1.1 Intended use

RoofVent® RG units are supply and extract air handling units for heating spaces up to 25 m in height with decentralised condensing gas boiler. They have the following functions:

- Fresh air supply
- Extract air removal
- Heating with condensing gas boiler
- Energy recovery with highly efficient plate heat exchanger
- Filtering of the fresh air and the extract air
- Air distribution and destratification with adjustable Air-Injector

RoofVent® RG units comply with all the requirements of the Ecodesign Directive 2009/125/EC relating to environmentally friendly design of ventilation systems. They are systems of the 'non-residential ventilation unit' (NRVU) and 'bidirectional ventilation unit' (BVU) type, provided for in Commission Regulation (EU) 1253/2014.

The Hoval TopTronic® C integrated control system ensures energy-efficient, demand-based operation of Hoval indoor climate systems.

Intended use also includes compliance with the operating instructions. Any usage over and above this use is considered to be not as intended. The manufacturer can accept no liability for damage resulting from improper use.

### 1.2 User group

The units are only allowed to be installed, operated and maintained by authorised and instructed personnel who are well acquainted with the units and are informed about possible dangers.

## 2 Construction and operation

### 2.1 Construction

The RoofVent® RG unit consists of the following components:

#### Roof unit with energy recovery

The self-supporting housing for mounting on the roof frame is of double-shell construction; this ensures good thermal insulation and high stability. The roof unit includes:

- the fans
- the fresh air filter
- the plate heat exchanger with control dampers
- the control block

All components are easily accessible for maintenance work through large access openings.

#### Gas boiler attachment

The gas boiler attachment contains:

- the Hoval TopGas® classic (80) gas condensing boiler
- the supply air/flue gas system
- the heated condensate drain with neutraliser
- the hydraulics with heating pump, diaphragm expansion vessel, safety valve and return temperature sensor

#### Below-roof unit

The below-roof unit is installed in the roof and projects into the hall. It consists of the following components:

- Connection module:
  - The connection module serves as an air duct through the roof and for drawing in extract air from the hall through the extract air grille. To enable easy adaptation to local installation conditions, the connection module is available in 4 lengths. It comprises:
    - the extract air filter
    - flow and return pipes of the heating circuit
    - the electrical connection box of the below-roof unit (with plug-in connection to the control block in the roof unit)
- Heating section:
  - The heating section contains the hot water coil for heating the supply air.
- Air-Injector:
  - The Air-Injector is a patented, infinitely variable vortex air distributor for the draught-free introduction of air into the hall under changing operating conditions.

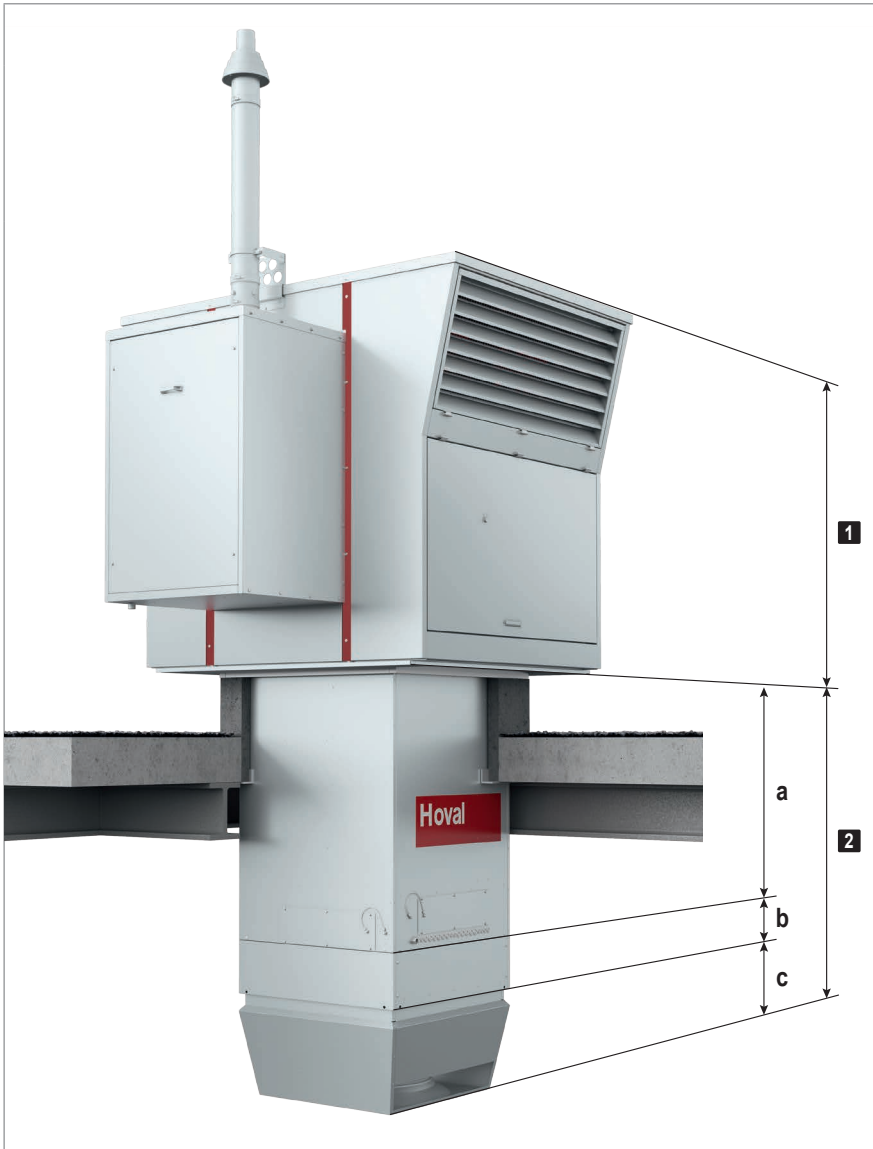

- 1** Roof unit with energy recovery and gas boiler attachment
- 2** Below-roof unit
  - a** Connection module
  - b** Heating section
  - c** Air-Injector

Fig. B1: RoofVent® RG components

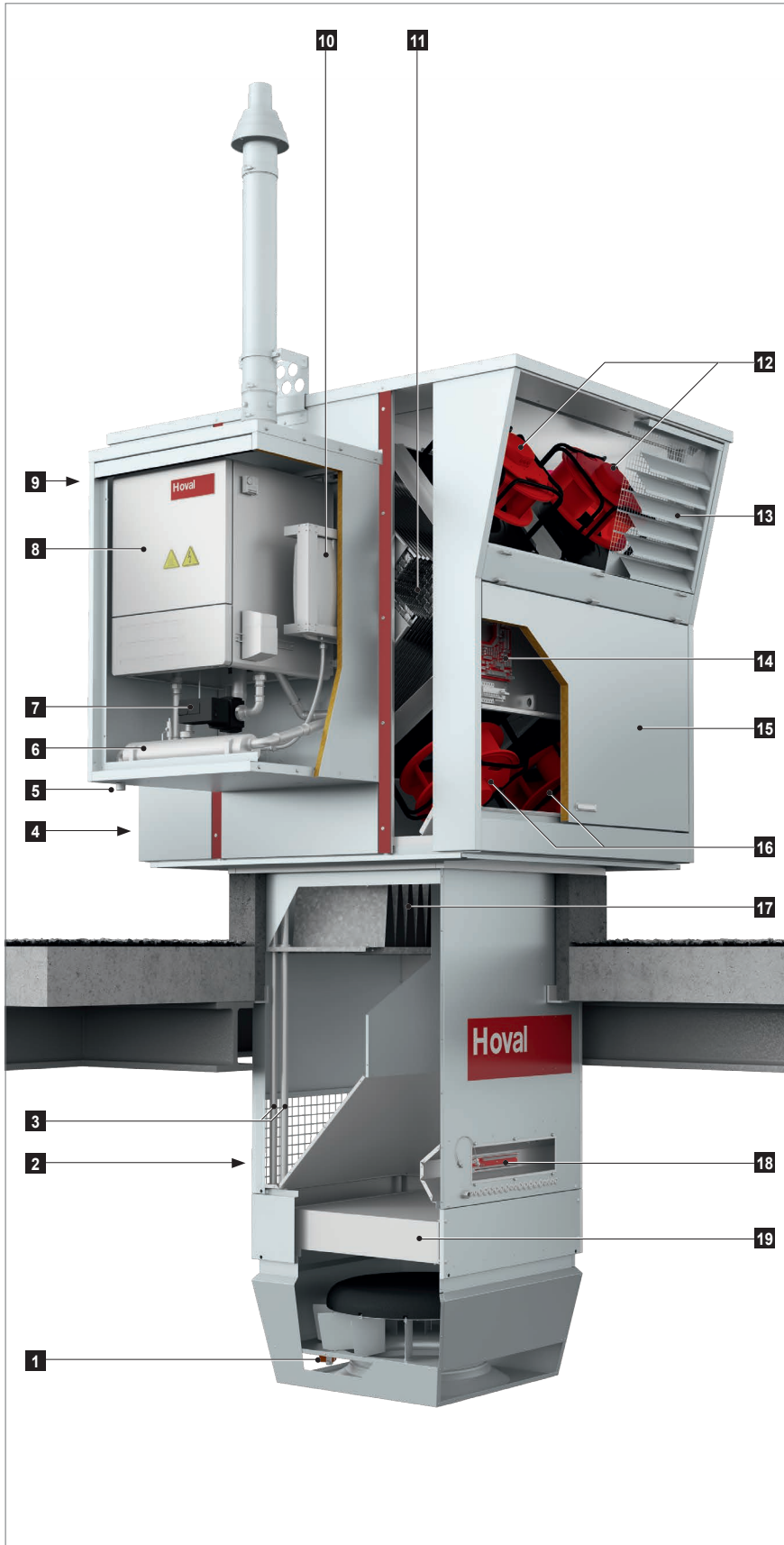

- |           |  |
|-----------|--|
| <b>1</b>  | Actuator Air-Injector  |
| <b>2</b>  | Extract air grille   |
| <b>3</b>  | Flow and return pipes  |
| <b>4</b>  | Extract air access door  |
| <b>5</b>  | Condensate drain gas boiler  |
| <b>6</b>  | Neutraliser  |
| <b>7</b>  | Heating pump   |
| <b>8</b>  | Condensing gas boiler  |
| <b>9</b>  | Fresh air access door<br>(access to the fresh air filter)                                    |
| <b>10</b> | Diaphragm expansion vessel   |
| <b>11</b> | Plate heat exchanger with bypass<br>(for performance control and as<br>recirculation bypass) |
| <b>12</b> | Exhaust air fans   |
| <b>13</b> | Exhaust air access door  |
| <b>14</b> | Control block  |
| <b>15</b> | Supply air access door   |
| <b>16</b> | Supply air fans  |
| <b>17</b> | Extract air filter   |
| <b>18</b> | Connection box   |
| <b>19</b> | Heating coil   |

Fig. B2: RoofVent® RG construction

2.2 Function diagram

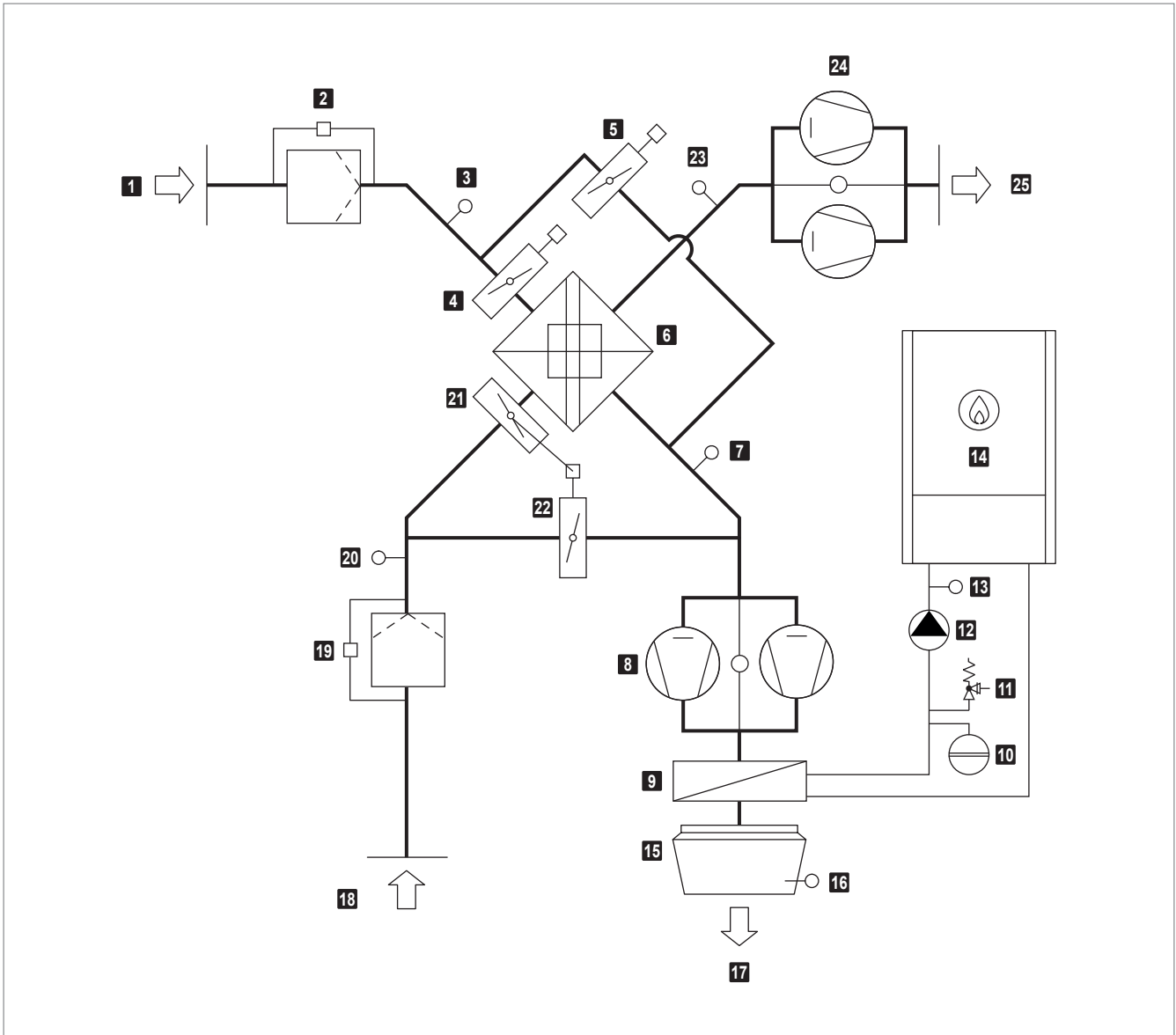

- |   |  |
|---|--|
| <b>1</b> Fresh air  | <b>14</b> Condensing gas boiler                                    |
| <b>2</b> Fresh air filter with differential pressure switch | <b>15</b> Air-Injector with actuator                               |
| <b>3</b> Temperature sensor air inlet ER (optional)         | <b>16</b> Supply air temperature sensor                            |
| <b>4</b> Fresh air damper with actuator                     | <b>17</b> Supply air   |
| <b>5</b> Bypass damper with actuator                        | <b>18</b> Extract air  |
| <b>6</b> Plate heat exchanger                               | <b>19</b> Extract air filter with differential pressure switch     |
| <b>7</b> Temperature sensor air outlet ER (optional)        | <b>20</b> Extract air temperature sensor                           |
| <b>8</b> Supply air fans with flow rate monitoring          | <b>21</b> Extract air damper with actuator                         |
| <b>9</b> Heating coil                                       | <b>22</b> Recirculation damper (opposed to the extract air damper) |
| <b>10</b> Diaphragm expansion vessel                        | <b>23</b> Exhaust air temperature sensor                           |
| <b>11</b> Safety valve                                      | <b>24</b> Exhaust air fans with flow rate monitoring               |
| <b>12</b> Heating pump                                      | <b>25</b> Exhaust air  |
| <b>13</b> Return temperature sensor                         |  |

Fig. B3: RoofVent® RG function diagram

### 2.3 Operating modes

The RoofVent® RG has the following operating modes:

- Ventilation
- Ventilation (reduced)
- Air quality
- Recirculation
- Exhaust air
- Supply air
- Standby

The TopTronic® C control system regulates these operating modes automatically for each control zone in accordance with the specifications in the calendar. The following points also apply:

- The operating mode of a control zone can be switched over manually.
- Each RoofVent® unit can operate individually in a local operating mode: Off, Recirculation, Supply air, Exhaust air, Ventilation.

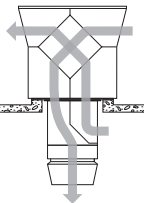
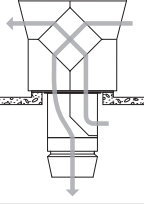
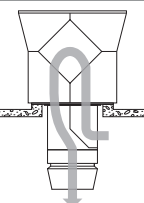
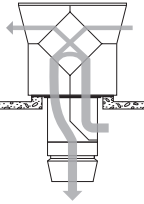
Code	Operating mode		Description
VE	<p><b>Ventilation</b></p> <p>The unit blows fresh air into the room and exhausts polluted room air. The room temperature set value day is active. Depending on the temperature conditions, the system continuously controls:</p> <ul style="list-style-type: none"> <li>■ the energy recovery</li> <li>■ the heating</li> </ul>		<p>Supply air fan ..... on <sup>1)</sup></p> <p>Exhaust air fan ..... on <sup>1)</sup></p> <p>Energy recovery ..... 0-100 %</p> <p>Extract air damper ..... open</p> <p>Recirculation damper ..... closed</p> <p>Heating ..... 0-100 %</p> <p><sup>1)</sup> Adjustable flow rate</p>
VEL	<p><b>Ventilation (reduced)</b></p> <p>As VE, but the unit only operates with the set minimum values for the supply and exhaust air volumes</p>		<p>Supply air fan ..... MIN</p> <p>Exhaust air fan ..... MIN</p> <p>Energy recovery ..... 0-100 %</p> <p>Extract air damper ..... open</p> <p>Recirculation damper ..... closed</p> <p>Heating ..... 0-100 %</p>
AQ	<p><b>Air quality</b></p> <p>This is the operating mode for demand-controlled ventilation of the room. The room temperature set value day is active. Depending on the temperature conditions, the system continuously controls:</p> <ul style="list-style-type: none"> <li>■ the energy recovery</li> <li>■ the heating</li> </ul> <p>Depending on the room air quality or room air humidity, the system operates in one of the following operating states:</p>		
AQ_REC	<ul style="list-style-type: none"> <li>■ Air quality Recirculation: When air quality is good and air humidity appropriate, the unit heats in recirculation operation.</li> </ul>		Like REC
AQ_ECO	<ul style="list-style-type: none"> <li>■ Air quality Mixed air: When ventilation requirements are medium, the unit heats in mixed air operation. The supply and exhaust air volume is based on the air quality.</li> </ul>		<p>Supply air fan ..... MIN-MAX</p> <p>Exhaust air fan ..... MIN-MAX</p> <p>Energy recovery ..... 0-100 %</p> <p>Extract air damper ..... 50 %</p> <p>Recirculation damper ..... 50 %</p> <p>Heating ..... 0-100 %</p>

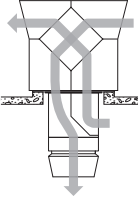
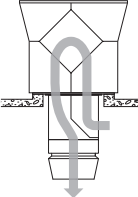
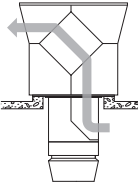
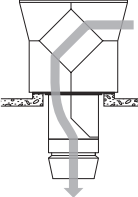
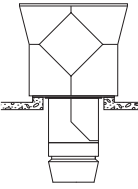
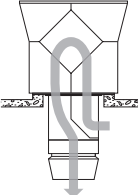
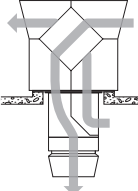
AQ_VE	<ul style="list-style-type: none"> <li>■ Air quality Ventilation: When ventilation requirements are high or the room air humidity is too high, the unit heats in pure ventilation operation. The supply and exhaust air volume is based on the air quality.</li> </ul>		Supply air fan ..... MIN-MAX Exhaust air fan ..... MIN-MAX Energy recovery ..... 0-100 % Extract air damper ..... open Recirculation damper ..... closed Heating ..... 0-100 %
REC  DES	<p><b>Recirculation</b> On/Off recirculation operation with TempTronic algorithm: During heat demand, the unit draws in room air, heats it and blows it back into the room. The room temperature set value day is active. The flow rate is controlled in 2 stages.</p> <ul style="list-style-type: none"> <li>■ Destratification: To avoid heat build-up under the ceiling, it may be appropriate to switch on the fan when there is no heat demand (either in permanent operation or in on/off operation depending on the temperature stratification, as desired).</li> </ul>		Supply air fan ..... 0 / MIN / MAX <sup>1)</sup> Exhaust air fan ..... off Energy recovery ..... 0 % Extract air damper ..... closed Recirculation damper ..... open Heating ..... on <sup>1)</sup>  <sup>1)</sup> Depending on heat demand
EA	<p><b>Exhaust air</b> The unit extracts spent room air. There is no room temperature control. Unfiltered fresh air enters the room through open windows and doors or another system provides air supply.</p>		Supply air fan ..... off Exhaust air fan ..... on <sup>1)</sup> Energy recovery ..... 0 % Extract air damper ..... open Recirculation damper ..... closed Heating ..... off  <sup>1)</sup> Adjustable flow rate
SA	<p><b>Supply air</b> The unit blows fresh air into the room. The room temperature set value day is active. Depending on the temperature conditions, the system controls the heating. Spent room air passes through open windows and doors or another system provides extraction.</p>		Supply air fan ..... on <sup>1)</sup> Exhaust air fan ..... off Energy recovery ..... 0 % <sup>2)</sup> Extract air damper ..... open Recirculation damper ..... closed Heating ..... 0-100 %  <sup>1)</sup> Adjustable flow rate <sup>2)</sup> Fresh air and bypass dampers are open
ST	<p><b>Standby</b> The unit is ready for operation. The following operating modes are activated if required:</p>		
CPR	<ul style="list-style-type: none"> <li>■ Cooling protection: If the room temperature drops below the set value for cooling protection, the unit heats up the room in recirculation operation.</li> </ul>		Supply air fan ..... MAX Exhaust air fan ..... off Energy recovery ..... 0 % Extract air damper ..... closed Recirculation damper ..... open Heating ..... on
NCS	<ul style="list-style-type: none"> <li>■ Night cooling: If the room temperature exceeds the set value for night cooling and the current fresh air temperature permits it, the unit blows cool fresh air into the room and extracts warmer room air.</li> </ul>		Supply air fan ..... on <sup>1)</sup> Exhaust air fan ..... on <sup>1)</sup> Energy recovery ..... 0 % Extract air damper ..... open Recirculation damper ..... closed Heating ..... off  <sup>1)</sup> Adjustable flow rate

<p><b>L_OFF</b></p>	<p><b>Off</b> (local operating mode) The unit is switched off.</p>		<p>Supply air fan ..... off Exhaust air fan ..... off Energy recovery ..... 0 % Extract air damper ..... closed Recirculation damper ..... open Heating ..... off</p>
<p>–</p>	<p><b>Forced heating</b> The unit draws in room air, warms it and blows it back into the room. For example, forced heating is suitable for heating the hall before taking the control system into operation or if the controller fails during the heating period. Connecting a room thermostat makes it possible to specify a room temperature set value. Forced heating can be activated and set as required by the Hoval service technician.</p>		<p>Supply air fan ..... MAX Exhaust air fan ..... off Energy recovery ..... 0 % Extract air damper ..... closed Recirculation damper ..... open Heating ..... on</p>

Table B1: RoofVent® RG operating modes



### 3 Technical data

#### 3.1 Type code

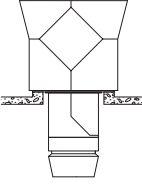
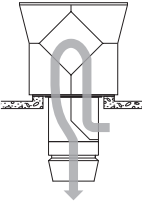
<b>RG - 9 Z - ...</b>	
<b>Unit type</b>	RoofVent® RG
<b>Unit size</b>	9
<b>Heating section</b>	Z with coil type Z
<b>Further options</b>	

Table B2: Type code

#### 3.2 Application limits

Fresh air temperature	min.	°C	-15
Extract air temperature	max.	°C	50
Moisture content of extract air <sup>1)</sup>	max.	g/kg	15
Supply air temperature	max.	°C	60
Temperature of the heating medium	max.	°C	85
Pressure of the heating medium	min.	kPa	200
	max.	kPa	300
Air flow rate	min.	m³/h	5000

<sup>1)</sup> Moisture increase in the room max. 2 g/kg

Table B3: Application limits

#### 3.3 Heat recovery system (HRS)

Temperature efficiency, dry	%	74
Temperature efficiency, wet	%	84

Table B4: Thermal transfer level of the plate heat exchanger

#### 3.4 Air filtration

Filter	Fresh air	Extract air
Class acc. to ISO 16890	ePM <sub>1</sub> 55 %	ePM <sub>10</sub> 60 %
Class acc. to EN 779	F7	M6
Factory setting of differential pressure switches	250 Pa	300 Pa

Table B5: Air filtration

#### 3.5 Electrical connection

Supply voltage	V AC	3 × 400
Permitted voltage tolerance	%	± 5
Frequency	Hz	50
Connected load	kW	8.31
Current consumption max.	A	14.20
Series fuse	A	20.0

Table B6: RoofVent® RG electrical connections

#### 3.6 Air flow rate

Nominal air flow rate	m³/h	8000
Floor area covered	m²	797

Table B7: Air flow rate

#### 3.7 Technical data of condensing gas boiler

Rated heating capacity at 80/60 °C	kW	13.4 – 71.8
Rated heating capacity at 50/30 °C	kW	14.8 – 79.1
Nominal heat input <sup>1)</sup>	kW	13.8 – 75.8
Water-side operating pressure	min.	kPa 100
	max. (PMS)	kPa 400
Test pressure (PT)	kPa	600
Boiler water volume (V <sub>(H2O)</sub> )	l	5.4
Minimum circulation water volume	l/h	550
Boiler efficiency	at 80/60 °C in full-load operation H <sub>i</sub> /H <sub>s</sub>	96.3/86.8
	at 30% partial load operation H <sub>i</sub> /H <sub>s</sub>	107.8/97.3
NO <sub>x</sub> class (EN 15502)	-	6
Nitrous oxide emission (EN 15502) (H <sub>s</sub> )	mg/kWh	29.0
CO <sub>2</sub> content in the flue gas min./max. output	%	8.8/8.8
Gas flow pressure min./max.	mbar	17.4 – 50
Gas connection values at 15 °C / 1013 mbar	Natural gas E (Wo = 15.0 kWh/m³) H = 9.97 kWh/m³	m³/h 1.4 – 7.6
	Natural gas LL (Wo = 12.4 kWh/m³) H = 8.57 kWh/m³	m³/h 1.6 – 8.8
Condensate quantity at 50/30 °C	l/h	7.1

<sup>1)</sup> Data relates to Hi. The boiler series is tested for EE/H setting. With a factory setting of a Wobbe number of 15.0 kWh/m³, operation in the Wobbe number range of 12.0 to 15.7 kWh/m³ is possible without readjustment.

Table B8: Technical data TopGas® classic (80)

3.8 Heat output

Fresh air temp.	- 5 °C				- 15 °C			
	Q	Q <sub>TG</sub>	H <sub>max</sub>	t <sub>s</sub>	Q	Q <sub>TG</sub>	H <sub>max</sub>	t <sub>s</sub>
Unit type	kW	kW	m	°C	kW	kW	m	°C
RG-9	70	57.9	11.9	39.5	70	51.8	12.5	37.2

Legend: Q = Coil heat output  
 Q<sub>TG</sub> = Output to cover fabric heat losses  
 H<sub>max</sub> = Maximum mounting height  
 t<sub>s</sub> = Supply air temperature

Reference: Room air: 18 °C  
 Extract air: 20 °C / 20 % rel. humidity  
 Heat transfer fluid: 34 % glycol (Protect Glycol E from Tevler)

Table B9: RoofVent® RG heat output



**Notice**

The output for coverage of the fabric heat losses (Q<sub>TG</sub>) allows for the ventilation heat requirement (Q<sub>V</sub>) and the energy recovery output (Q<sub>ER</sub>) under the respective air conditions. The following applies:

$$Q + Q_{ER} = Q_V + Q_{TG}$$

3.9 Sound level

Position		1	2	3	4	
Sound pressure level (at a distance of 5 m) <sup>1)</sup>	dB(A)	40	54	48	41	
Total sound power level	dB(A)	62	76	70	63	
Octave sound power level	63 Hz	dB	42	44	42	42
	125 Hz	dB	53	61	58	54
	250 Hz	dB	55	64	60	56
	500 Hz	dB	57	69	64	58
	1000 Hz	dB	54	72	67	55
	2000 Hz	dB	53	69	64	54
	4000 Hz	dB	48	63	57	48
	8000 Hz	dB	40	57	50	41

1) With hemispherical radiation in a low-reflection environment

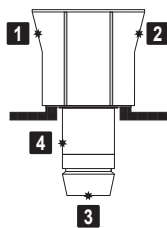

- 1 Fresh air
- 2 Exhaust air
- 3 Supply air
- 4 Extract air

Table B10: RoofVent® RG sound level

## 3.10 Product information according to ErP

Trademark / Model		Hoval RoofVent® RG	Unit
Type		NRVU, BVU	–
Drive		Variable speed drive	–
Heat recovery system		other	–
Thermal efficiency of heat recovery ( $\eta_{t, nrvu}$ )		74	%
Nominal flow rate ( $q_{nom}$ )		2.22	m <sup>3</sup> /s
Effective electric power input (P)		2.75	kW
Internal specific fan power (SFP <sub>int</sub> )		812	W/(m <sup>3</sup> /s)
Face velocity		2.98	m/s
Nominal external pressure ( $\Delta p_{s, ext}$ )	Supply air	350	Pa
	Extract air	320	
Internal pressure drop of ventilation components ( $\Delta p_{s, int}$ )	Fresh air/supply air	226	Pa
	Extract air/exhaust air	261	
Static efficiency of the fans ( $\eta_{fan}$ ) in accordance with Regulation (EU) No 327/2011		60	%
Maximum leakage rate	External	0.25	%
	Internal	1.20	
Energy classification of the filters (class acc. to ISO 16890, final pressure difference)	Supply air ePM <sub>1</sub> 55 %	250	Pa
	Extract air ePM <sub>10</sub> 60 %	300	
Visual filter warning		Displayed on the operating unit	–
Casing sound power level (L <sub>WA</sub> )		72	dB
Disassembly instructions		Devices that are no longer functional must be dismantled by a specialist company and disposed of at suitable collection points.	–
Contact details		Hoval Aktiengesellschaft Austrasse 70, 9490 Vaduz, Liechtenstein www.hoval.com	

Table B11: Product information according to Commission Regulation (EU) 1253/2014, Article 4(2)

3.11 Dimensions and weights

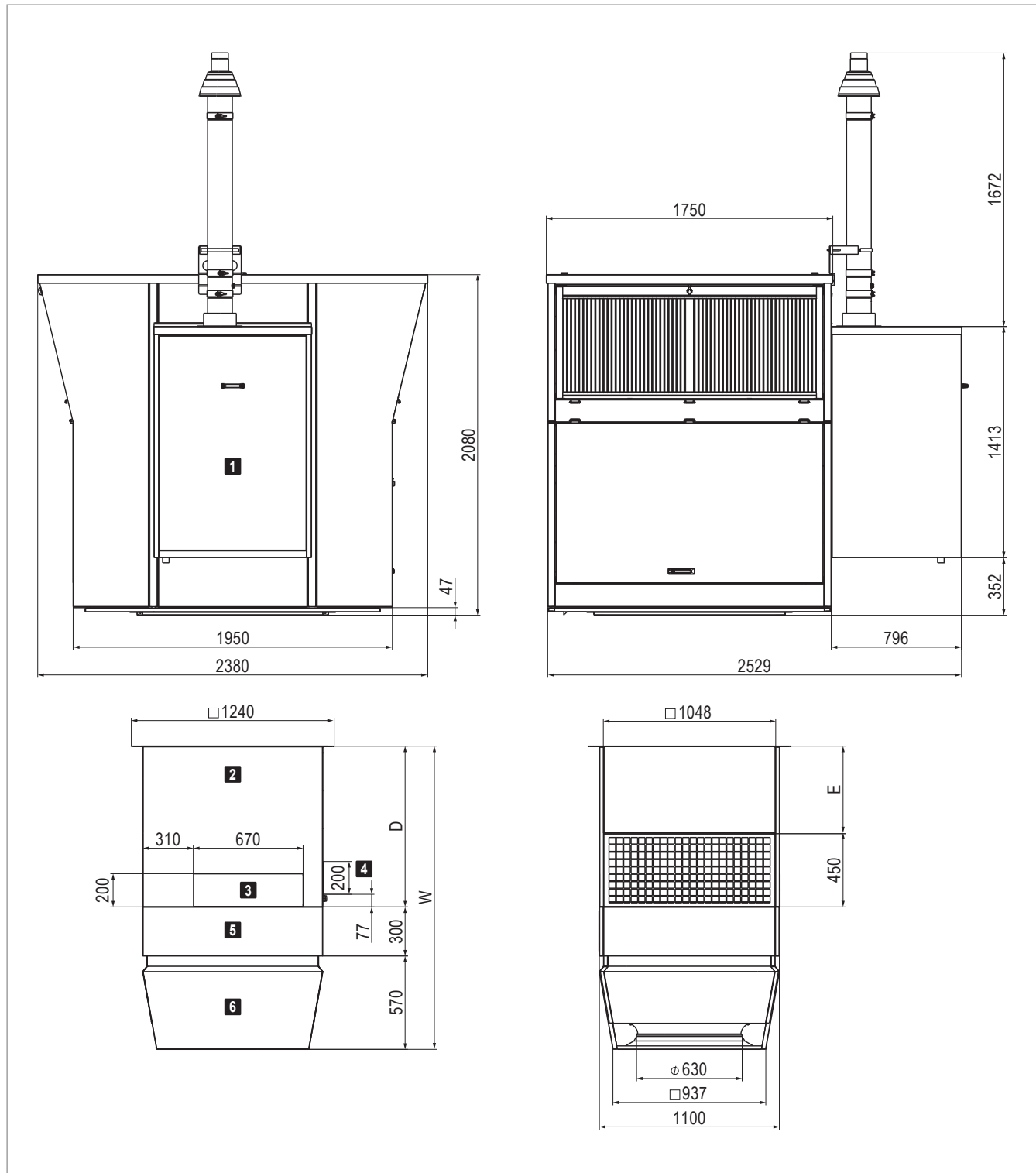

- 1** Roof unit with energy recovery and gas boiler attachment
- 2** Connection module
- 3** Access panel, coil

- 4** Access panel, connection box
- 5** Heating section
- 6** Air-Injector

Fig. B4: RoofVent® RG dimensional drawing (dimensions in mm)

Connection module		V0	V1	V2	V3
D	mm	980	1230	1480	1980
E	mm	530	780	1030	1530
W	mm	1850	2100	2350	2850

Table B12: RoofVent® RG dimensions

Unit type		RG-9
<b>Total</b>	<b>kg</b>	<b>1251</b>
Roof unit	kg	1050
Below-roof unit	kg	201
Air-Injector	kg	56
Heating section	kg	51
Connection module V0	kg	94
Additional weight V1	kg	+ 13
Additional weight V2	kg	+ 26
Additional weight V3	kg	+ 52

Table B13: RoofVent® RG weights

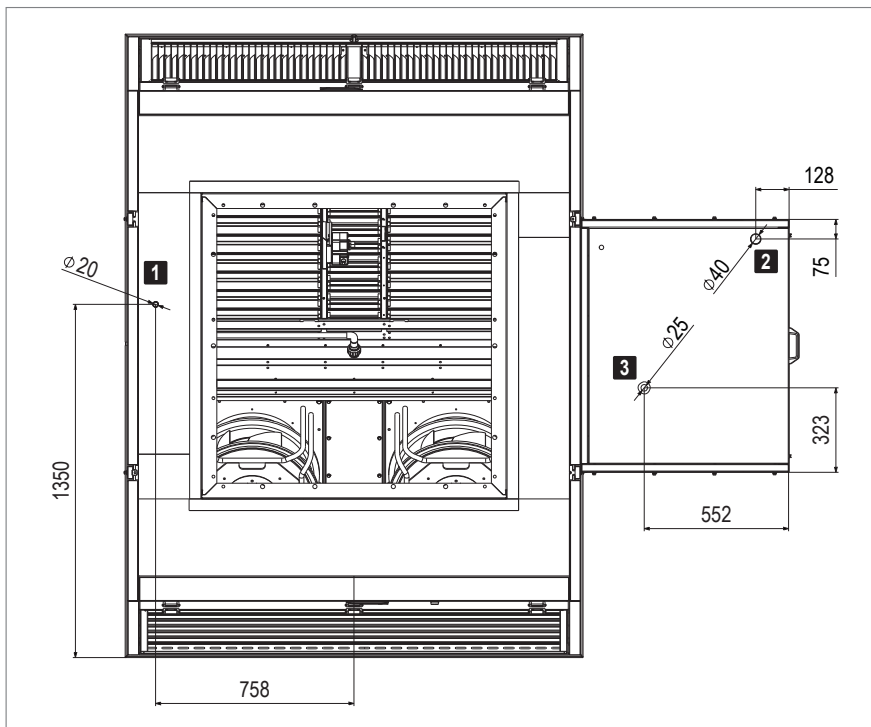

- 1** Condensate drain plate heat exchanger
- 2** Condensate drain gas boiler
- 3** Feedthrough of the gas supply line

Fig. B5: Dimension sheet for condensate drain and gas supply line (view of roof unit from below, dimensions in mm)

## 4 Specification texts

### 4.1 RoofVent® RG

Supply and extract air handling unit for heating rooms up to 25 m in height with decentralised condensing gas boiler; equipped with highly efficient air distributor; maximum floor area reached per unit 797 m<sup>2</sup>.

The unit consists of the following components:

- Roof unit with energy recovery with gas boiler attachment
- Below-roof unit:
  - Connection module
  - Heating section
  - Air-Injector
- Control components
- Optional components

The RoofVent® RG unit complies with all the requirements of the Ecodesign Directive 2009/125/EC relating to environmentally friendly design of ventilation systems. It is a system of the 'non-residential ventilation unit' (NRVU) and 'bidirectional ventilation unit' (BVU) type, provided for in Commission Regulation (EU) 1253/2014.

---

#### Roof unit with energy recovery and gas boiler attachment

---

Self-supporting housing, made of aluminium (outside) and magnesium-zinc sheet and aluminium (inside):

- Weatherproof, corrosion resistant, impact resistant, air-tight
- Low flammability, double-shelled, without heat bridges, with highly efficient insulation made of expanded polystyrene
- Hygienic and easy to maintain because of smooth interior surfaces and large access doors with ageing-resistant, silicone-free sealing materials

The roof unit with energy recovery includes:

#### Supply air and exhaust air fans

Designed as maintenance-free, direct-drive radial fans with high-efficiency EC motor, backwards-curved, 3D contoured blades and a free-running rotating wheel made of a high-performance composite material; inflow nozzle with optimised flow; infinitely variable speed; with active pressure registration for constant volumetric flow control and/or demand-controlled volumetric flow adjustment; low-noise; with integrated overload protection.

#### Fresh air filter

Designed as highly efficient compact filter elements, class ISO ePM<sub>1</sub> 55 % (F7), fully incinerable, easy to change, including differential pressure switch for filter monitoring.

#### Plate heat exchanger

Crossflow plate heat exchanger made of high-quality aluminium as a highly efficient, recuperative heat recovery system, certified by Eurovent, zero-maintenance, without moving parts, failsafe, hygienically harmless, no cross-contamination of impurities and odours. Equipped with bypass, recirculation bypass, condensate drain and condensation trap to the roof. The following dampers are arranged on the exchanger package:

- Fresh air and bypass dampers, each with their own actuator, for infinitely variable control of the heat recovery; with shut-off function by spring return.
- Extract air and recirculation dampers, interlinked in a counter-rotating arrangement with a common actuator, for controlling the recirculation and mixed air operation; with shut-off function by spring return.

All dampers correspond to seal integrity class 2 according to EN 1751.

#### Access openings

- Fresh air access door: large access opening with integrated weather and bird protection, configured with quick locking system for easy access to the fresh air filter, the plate heat exchanger as well as the fresh air and bypass dampers.
- Exhaust air access door: large, lockable access opening with integrated weather and bird protection for easy access to the exhaust air fans.
- Extract air access door: large access opening, configured with quick locking system and telescopic support for easy access to the extract air filter, the plate heat exchanger, the condensation trap as well as the extract air and recirculation dampers.
- Supply air access door: large, lockable access opening, configured with telescopic support for easy access to the supply air fans, the control block and the condensate collecting channel.

#### Control block

Compact design on an easily accessible mounting plate, comprising:

- Unit controller as part of the TopTronic® C control system:
  - Fully wired to the electrical components of the roof unit (fans, actuators, temperature sensors, filter monitoring, differential pressure sensor, boiler control)
  - Pluggable wiring to the control box in the connection module
- High-voltage section:
  - Mains power terminals
  - Isolation switch
  - Button for stopping the fans during filter change
- Low-voltage section:
  - Transformer for actuators, sensors and the unit controller
  - Externally switchable forced heating
  - Externally switchable forced off

- Circuit board with further electronic components for unit control (differential pressure measurement, fuses for the transformer, fuses for low voltage, ...)

#### Gas boiler attachment

Housing made of magnesium zinc sheet, insulated on the inside. The gas boiler attachment contains:

- TopGas® classic (80) gas condensing boiler with cast aluminium combustion chamber, corrosion-resistant aluminium-silicon alloy heat exchanger and boiler control. The following components are installed:
  - Pressure gauge
  - Water pressure monitor for lack of water protection
  - Flue gas temperature sensor with flue gas temperature limiting function
  - Automatic quick exhaust valve
  - Pre-mixing surface burner made of stainless steel, modulating with gas-air composite control
  - Automatic ignition and ionisation monitoring
  - Gas pressure monitor
  - Minimum circulation water volume required (550 l/h)
- Concentric supply air/flue gas system in element construction for quick assembly, painted white (RAL 9016)
- Heated condensate drain with neutraliser
- Hydraulics with heating pump, diaphragm expansion vessel, safety valve and return temperature sensor

#### Connection module

Housing made of magnesium-zinc sheet, air-tight, flame retardant, hygienic and easy to maintain because of smooth interior surfaces and ageing-resistant, silicone-free sealing materials; configured with extract air grille and access panel for easy access to the coil for maintenance. The connection module contains:

- Extract air filter, configured as a bag filter, class ISO ePM<sub>10</sub> 60% (M6), fully incinerable, easy to change, including differential pressure switches for filter monitoring
- Flow and return pipes of the heating circuit
- Laced wiring harness protected in a sheet metal duct, with direct plug connection to the control block in the roof unit
- Connection box made of galvanised sheet steel, configured with circuit board, screw-on cover and cable lead-ins with splash water protection and strain relief; for connection of:
  - Power supply
  - Zone bus
  - All sensors and actuators of the below-roof unit (ready-to-connect): supply air temperature sensor, Air-Injector actuator
  - Optional components as required

#### Connection module V1 / V2 / V3:

The connection module is extended for adapting to the local installation situation.

#### Heating section

Housing made of magnesium zinc sheet, air-tight, flame retardant, hygienic and easy to maintain because of ageing-resistant, silicone-free sealing materials, configured with access panel for access to the drain tap. The heating section contains:

- the highly efficient heating coil consisting of seamless copper pipes with pressed-on, optimised and profiled aluminium fins and manifolds made of copper; connected to the flow and return pipes in the connection module
- the drain tap

#### Air-Injector

##### 1 Air-Injectors

Housing made of magnesium zinc sheet, air-tight, flame retardant, hygienic and easy to maintain because of ageing-resistant, silicone-free sealing materials, with:

- Vortex air distributor with concentric outlet nozzle, adjustable vanes and integrated absorber hood
- Actuator for infinitely variable adjustment of the air distribution from vertical to horizontal
  - for draught-free air distribution in the hall under changing operating conditions
  - for the rapid and large-area reduction of temperature stratification in the room through induction of secondary air and strong mixing of the room air with supply air
- Supply air temperature sensor

##### 2 Air-Injectors

2x Air-Injectors, supplied loose; supply air duct for connecting the RoofVent® unit to the Air-Injectors on site. Housing made of magnesium zinc sheet, air-tight, flame retardant, hygienic and easy to maintain because of ageing-resistant, silicone-free sealing materials, with:

- Vortex air distributor with concentric outlet nozzle, adjustable vanes and integrated absorber hood
- Actuator for infinitely variable adjustment of the air distribution from vertical to horizontal
  - for draught-free air distribution in the hall under changing operating conditions
  - for the rapid and large-area reduction of temperature stratification in the room through induction of secondary air and strong mixing of the room air with supply air
- Supply air sensor (supplied in the connection module)

##### Without Air-Injector

Unit configured without vortex air distributor for connection to an on-site supply air duct and air distribution within the building, supply air temperature sensor supplied in the connection module.

## Options

### Paint finish of below-roof unit

Exterior painting of the below-roof unit in choice of RAL colour, including optional components.

### Fresh air and exhaust air silencers

Fresh air silencer configured as add-on part for the roof unit which can be folded downwards, housing made of aluminium with a bird screen and acoustic insulation lining, for reducing sound emissions on the fresh air side; exhaust air silencer configured as add-on part for the roof unit which can be folded downwards, housing made of aluminium with bird screen and easily accessible sound attenuation splitters, optimised flow, with abrasion-resistant and easily cleaned surfaces, non-flammable, hygienically clean with high-quality glass filament cover for reducing sound emissions on the exhaust air side, insertion loss fresh air/exhaust air \_\_\_\_ dB / \_\_\_\_ dB

### Supply air and extract air silencers

Supply air silencer configured as separated component in the below-roof unit, flow-optimised sound attenuation splitters, with abrasion-resistant and easily cleaned surfaces, non-flammable, hygienically clean with high-quality glass filament cover, extract air silencer configured as acoustic insulation lining in the connection module, for reducing sound emission in the room, insertion loss supply air/extract air \_\_\_\_ dB / \_\_\_\_ dB

### Condensate drain inside

Heated condensate drain line from the gas condensing boiler inside the RoofVent® unit to the drain connection in the connection module.

### Energy monitoring

Consisting of 2 additional temperature sensors for recording the air inlet and air outlet temperatures of the plate heat exchanger. Energy monitoring makes it possible to display the energy saved by heat recovery.

## 4.2 TopTronic® C – System control

Zone-based control system for the energy-optimised operation of decentralised Hoval indoor climate systems. Maximum system size per system bus: 64 control zones with up to 10 supply and extract air handling units or supply air handling units and 10 recirculation air handling units each.

### Zone allocation

Configured in advance for the customer at the factory:

	Room designation	Unit type
Zone 1:	_____	_____
Zone 2:	_____	_____
...		

### System structure

- Zone control panel made of coated sheet steel (light grey RAL 7035), ... x ... x ... mm, with:
  - System operator terminal
  - Fresh air temperature sensor
  - 1 zone controller and 1 room temperature sensor per zone (expandable to up to 4 room temperature sensors per zone)
  - Safety relay
  - Electrical cabinet internally pre-wired, all components routed to terminals
- Zone bus: as serial bus for communication with all controllers in one control zone, with robust bus protocol via shielded, twisted bus cable (provided by the client)
- Unit controller: installed in the particular indoor climate unit, works autonomously according to the specifications of the zone controller
- Heating/cooling demand per zone with feedback monitoring

### Functions, standard

- Zone-based autonomous room control. Temperature and ventilation control separately adjustable for each zone
- Room temperature control via room-supply air cascade by means of energy-optimised double sequence control with priority circuit for energy recovery (supply and extract air handling units)
- Intelligent automatic heating to reach the desired room temperature at the switching time
- 5 adjustable room temperature set values per zone:
  - Cooling protection (lower setpoint in standby)
  - Overheating protection (upper setpoint in standby)
  - Room set value winter
  - Room set value summer
  - Night cooling set value (free cooling) (supply and extract air handling units)
- Destratification mode for even temperature distribution



- Main operating modes of supply and extract air handling units:  
VE .... Ventilation, infinitely variably adjustment  
AQ.... Air quality, automatic control with Hoval combination sensor (option), optional reference variable:
    - CO<sub>2</sub> or VOC
    - Air humidity (optimised dehumidification mode)
  - REC . Recirculation, infinitely variably adjustment
  - DES.. Destratification
  - EA .... Exhaust air, infinitely variably adjustment
  - SA .... Supply air, infinitely variably adjustment
  - ST .... Standby
- Main operating modes of supply air units:  
REC . Recirculation, infinitely variably adjustment
  - DES.. Destratification
  - SA .... Supply air, infinitely variably adjustment  
With Hoval combination sensor (option) also demand-driven control of the fresh air ratio, optional reference variable CO<sub>2</sub> or VOC
  - ST .... Standby
- Main operating modes of recirculated air units:  
REC . Recirculation, infinitely variably adjustment
  - DES.. Destratification
  - ST .... Standby
- Forced heating (construction site heating) can be activated on each device before completion of the overall system (activation by Hoval service technician)
  - Control of draught-free air distribution with the Hoval Air-Injector: the discharge direction is adjusted infinitely variably and automatically according to the respective operating condition and the existing temperatures (heating/cooling).

#### Operation

- TopTronic® C-ST system operator terminal: touch panel for visualisation and control of all Hoval indoor climate units registered on the bus

#### Options for operation

- Hoval C-SSR operating software, for visualisation on customer's PC
- TopTronic® C-ZT as zone operator terminal: for simple on-site operation of a control zone
- Manual operating selector switches
- Manual operating selector buttons
- Operating of the units via building management system via standardised interfaces:
  - BACnet
  - Modbus IP
  - Modbus RTU

#### Alarms, protection

- Central alarm management with registration of all alarms (timestamp, priority, status) in an alarm list and alarm memory of the last 50 alarms; forwarding via e-mail can be set in the parameters.
- If there is a failure of communication, bus stations, sensor systems or supply media, each part of the system transitions to a protection mode which safeguards operation.
- A maintenance mode implemented in the control algorithm for testing all physical data points and alarms guarantees high reliability.
- Pre-programmed data points retrievable via logger function for 1 year

#### Options for the zone control panel

- Alarm lamp
- Socket

#### Per zone:

- The change-over between heating and cooling can be either automatic or manual
  - Cooling lock switch for automatic changeover
  - Heating/cooling switch for manual changeover
- Additional room temperature sensors (max. 3)
- Combination sensor room air quality, temperature and humidity
- Combination sensor fresh air temperature and humidity
- Transfer of actual values and setpoints from external systems (0...10 V; 4 - 20 mA)
- Load shedding input
- Signal for external extract air fan
- Operating selector switches on terminal
- Operating selector button on terminal
- Control of distributor pump, incl. power supply

#### Power distribution:

- Circuit breakers and output terminals for Hoval indoor climate units
- Safety relay (4-pin)





**Options**

1 Type code . . . . .26

2 Connection module. . . . .28

3 Design with 2 Air-Injectors . . . . .28

4 Design without Air-Injector . . . . .28

5 Paint finish of below-roof unit . . . . .28

6 Fresh air and exhaust air silencers . . . . .29

7 Supply air and extract air silencers . . . . .30

8 Condensate drain inside. . . . .30

9 Energy monitoring . . . . .30

10 Return temperature sensor . . . . .30

## 1 Type code

RG - 9 Z - -RY / ST . - - / V0 . D1 . LU / AF . SI / - . - . CI . - - / TC . EM . - - . RF

### Unit type

RoofVent® RG

### Unit size

9

### Heating section

Z with coil type Z

### Heat recovery

RY Temperature efficiency ErP 2018

### Design

ST Standard

### Connection module

- V0 Standard
- V1 Length + 250 mm
- V2 Length + 500 mm
- V3 Length + 1000 mm

### Air outlet

- D1 Design with 1 Air-Injector
- D2 Design with 2 Air-Injectors
- D0 Design without Air-Injector

### Paint finish

- without
- LU Paint finish of below-roof unit

### Silencers outside

- without
- AF Fresh air and exhaust air silencers

### Silencers inside

- without
- SI Supply air and extract air silencers

### Condensate drain of condensing gas boiler

- Standard (onto the roof)
- CI Condensate drain inside

RG - 9 Z - -RY / ST . -- / V0 . D1 . LU / AF . SI / - . . -- . CI . -- / TC . EM . -- . RF

**Control system**

TC TopTronic® C

**Energy monitoring**

-- without

EM Energy monitoring

**Return temperature sensor**

RF Return temperature sensor

Table C1: Type code

## 2 Connection module

The connection module is available in 4 lengths for adapting the RoofVent® unit to local conditions.

## 3 Design with 2 Air-Injectors

To distribute the supply air over a very wide area, a supply air duct provided by the client can be connected to the RoofVent® unit. 2 Air-Injectors can be installed on this. Please note the following:

- 2 air distributors size 6 are supplied.
- Install the 2 air distributors on the supply air duct.
- Wire up the 2 actuators of the air distributors to the connection box.
- The supply air temperature sensor is enclosed. Install it in the supply air duct and wire it up to the connection box.

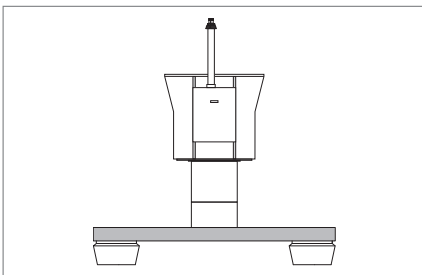

Fig. C1: RoofVent® unit with supply air duct and 2 Air-Injectors

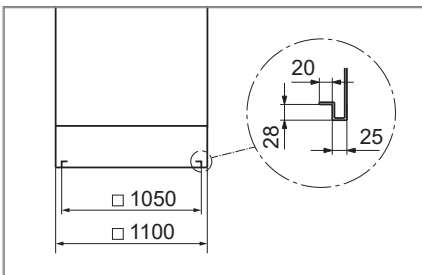

Fig. C2: Connection dimensions supply air duct (in mm)

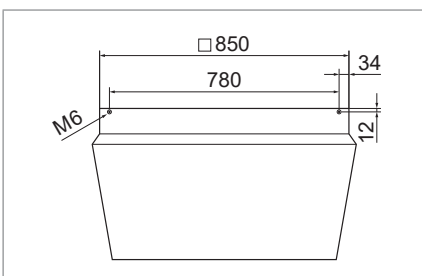

Fig. C3: Hole pattern for Air-Injector (dimensions in mm)

## 4 Design without Air-Injector

RoofVent® units in the design without Air-Injector are suitable for connecting to an air distribution system supplied by the client. Please note the following:

- The supply air temperature sensor is enclosed. Install it in the supply air duct and wire it up to the connection box.

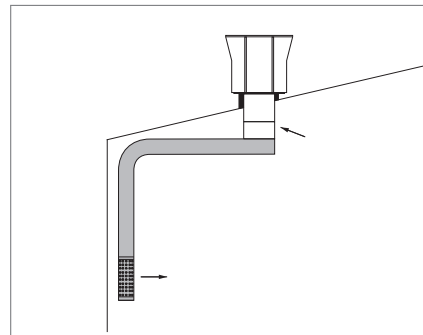

Fig. C4: Connection to an air distribution system supplied by the client (for dimensions see Fig. C2).

## 5 Paint finish of below-roof unit

The entire below-roof unit including optional components is painted in any colour.

## 6 Fresh air and exhaust air silencers

The fresh air silencer reduces noise emissions from RoofVent® units on the fresh air side. It consists of an aluminium casing with a bird screen and acoustic insulation lining and is configured as an add-on part for the roof unit which can be folded downwards.

The exhaust air silencer reduces noise emissions from RoofVent® units on the exhaust air side. It consists of an aluminium casing with a bird screen and sound attenuation splitters and is configured as an add-on part for the roof unit which can be folded downwards.

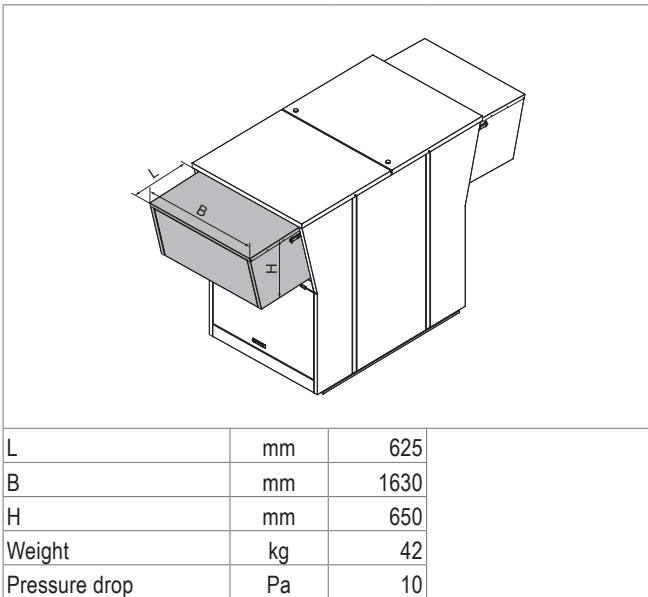

Table C2: Technical data fresh air silencer

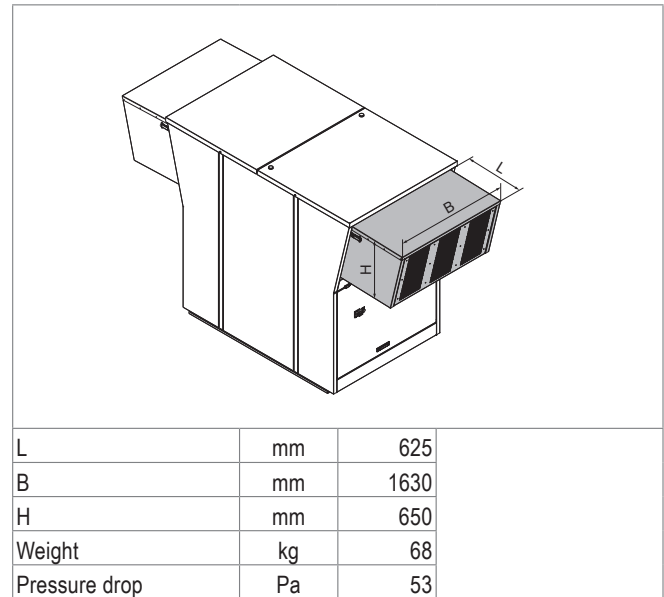

Table C4: Technical data exhaust air silencer

Frequency [Hz]	dB
63	0
125	1
250	3
500	4
1000	4
2000	4
4000	3
8000	3
<b>Total</b>	<b>3</b>

Table C3: Insertion attenuation fresh air silencer (values in dB, relating to the nominal air flow rate)

Frequency [Hz]	dB
63	2
125	3
250	9
500	11
1000	15
2000	14
4000	10
8000	8
<b>Total</b>	<b>11</b>

Table C5: Insertion attenuation exhaust air silencer (values in dB, relating to the nominal air flow rate)

## 7 Supply air and extract air silencers

Supply air and extract air silencers reduce the noise from RoofVent® units within the room. The supply air silencer is designed as a separated component and is installed above the Air-Injector. The extract air silencer consists of acoustic insulation lining in the connection module.

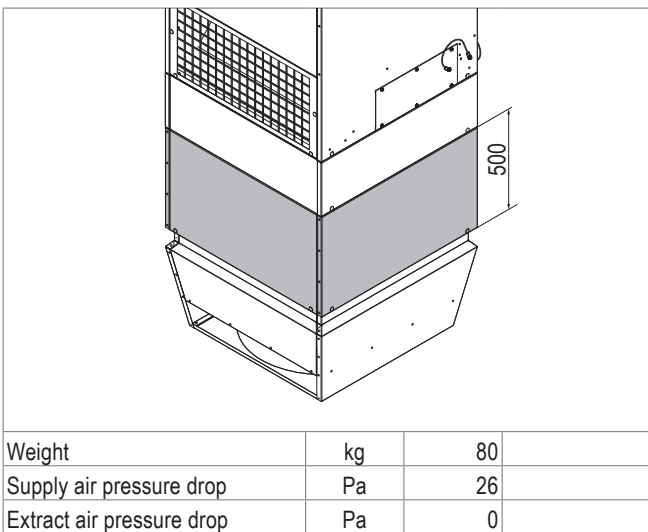

Table C6: Technical data supply air and extract air silencers

Frequency [Hz]	Supply air	Extract air
63	5	0
125	7	0
250	15	2
500	17	3
1000	20	3
2000	17	3
4000	12	2
8000	9	2
<b>Total</b>	<b>15</b>	<b>2</b>

Table C7: Insertion attenuation supply and extract air silencers (values in dB, relating to the nominal air flow rate)



### Notice

The option 'Supply air and extract air silencer' is not available with a connection module in the length V0, but only in the lengths V1, V2 and V3.

## 8 Condensate drain inside

The neutralised condensate from the gas condensing boiler can be channelled inside the RoofVent® unit to the drain connection in the connection module. To prevent icing of the condensate, the condensate line is heated.

- Install a condensate drain in accordance with the local provisions.
- Connection: External thread G 3/4"

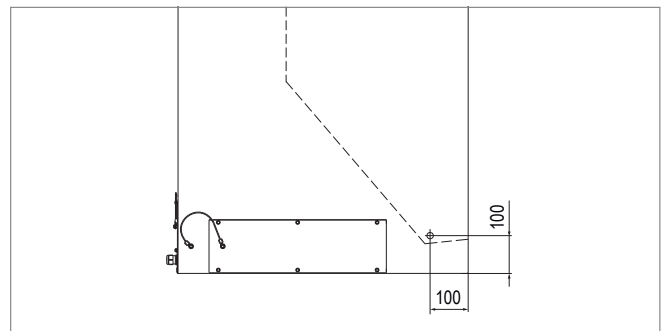

Fig. C5: Dimension sheet for condensate connection in the connection module

## 9 Energy monitoring

Energy monitoring makes it possible to display the energy saved by heat recovery. For this purpose, 2 additional temperature sensors are installed in the RoofVent® units; they record the air inlet and air outlet temperatures of the plate heat exchanger.

## 10 Return temperature sensor

The return temperature sensor monitors the return temperature of the heating medium.



### Notice

RoofVent® RG units are equipped with a return temperature sensor in the gas boiler attachment as standard.



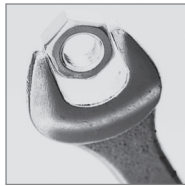

**Transport and installation**

1 Installation . . . . .	.32
2 Hydraulic installation . . . . .	.36
3 Gas connection . . . . .	.36
4 Electrical installation . . . . .	.37

# 1 Installation

## 1.1 Preparation

The following guidelines are important when preparing for installation:

- The scope of delivery includes:
  - RoofVent® unit, delivered in 2 parts on pallets (roof unit, below-roof unit)
  - Accessories (transport eyes, installation material, extract air filter, trap, temperature sensors, components of the flue gas line, metal tubes, heat transfer fluid)
  - Optional components
- The units are delivered screwed onto the pallet. To loosen the screws, the inspection doors must be opened. When unloading the units, make sure that there is enough space to open the inspection doors.
- The units are installed in or on the roof. A crane or helicopter is required.
- Transport eyes are supplied for lifting the below-roof unit and the roof unit.
  - A ladder will be required to screw in the transport eyes.
  - Use lifting ropes at least 2 m in length to lift the below-roof unit.
  - Use lifting ropes at least 3 m in length to lift the roof unit.
- Depending on the unit size, the below-roof unit can be delivered in 2 parts.
- Make sure that the roof frame corresponds to the specifications in chapter 1.3.
- A sealing compound is required for sealing (e.g. Sikaflex® 221).
- Define the desired orientation of the units.
- Fresh air and exhaust air silencers are supplied separately. Install them on the unit before transporting it to the roof, and make sure they are locked.
- Follow the installation instructions included.



**Notice**

Provide suitable protective devices and make sure the units can be accessed easily. The maximum roof load of the RoofVent® units is 80 kg.

## 1.2 Positioning

- Comply with the minimum and maximum distances.
- Pay attention to the alignment of the units relative to each other. Units must not draw in exhaust air from other units as fresh air.
- All air inlet and air outlet openings must be freely accessible. The supply air jet must be free to spread out unhindered.
- The access doors in the roof unit and the access panels in the below-roof unit must be easily accessible.
- Clearance of at least 0.9 m is required for maintenance work around the heating section.

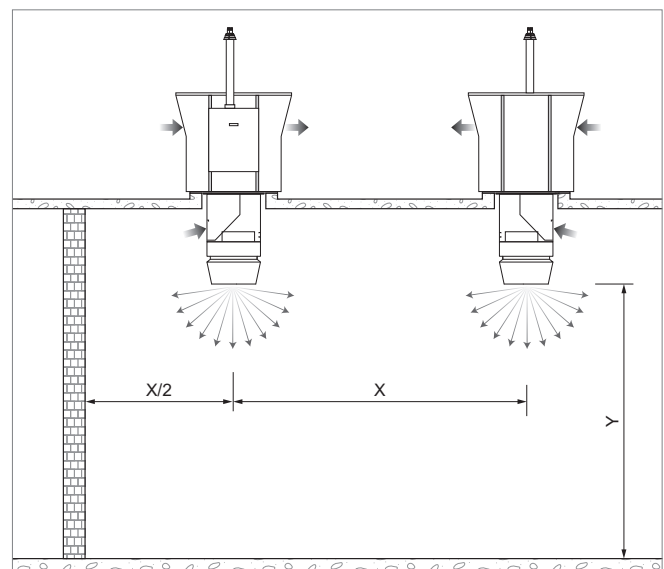

Distance X	min.	m	13
	max.	m	28
Mounting height Y	min.	m	5
	max. <sup>1)</sup>	m	Approx. 9...25

1) The maximum mounting height varies depending on the boundary conditions (for values, see table of heat outputs or calculation with the 'HK-Select' selection program)

Table D1: Minimum and maximum distances

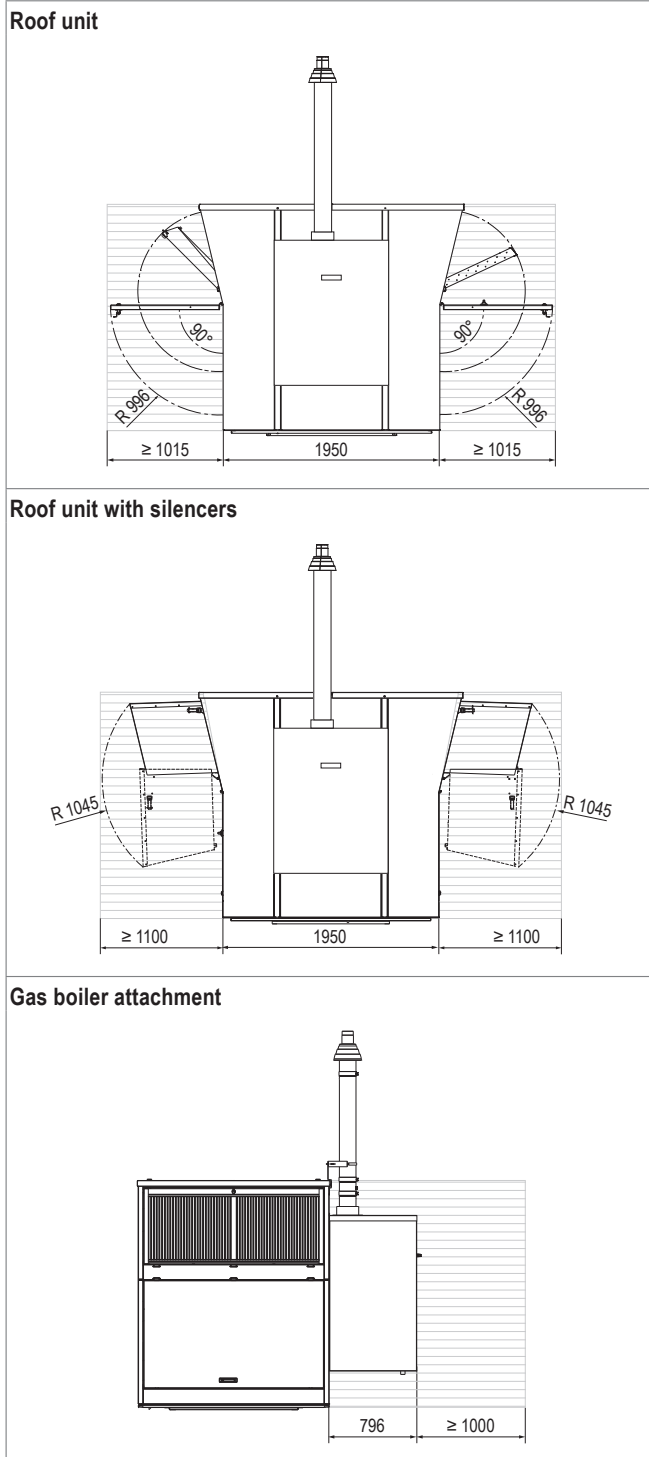

Fig. D1: Space requirements for maintenance on the roof (dimensions in mm)

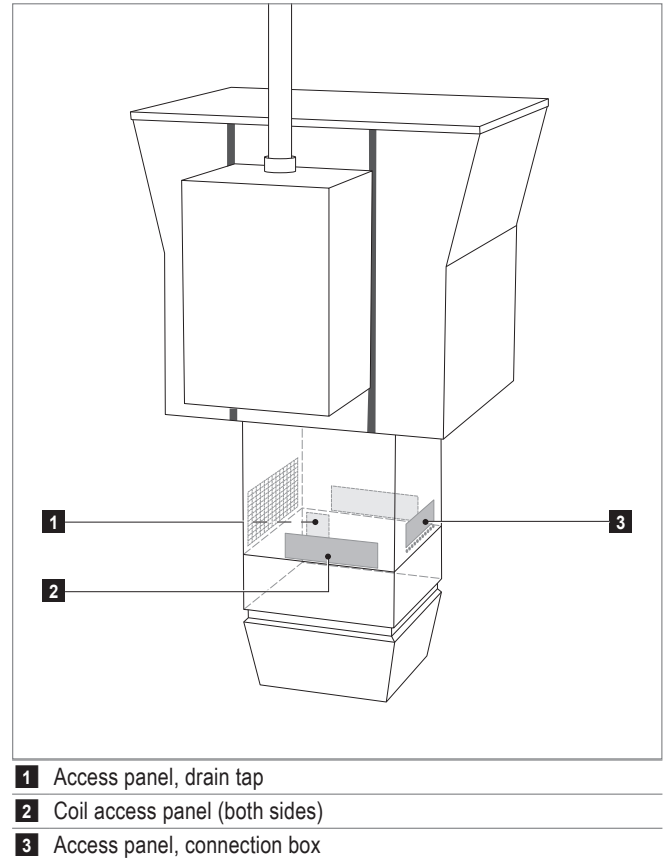

Fig. D2: Position of the access panels in the below-roof unit



**Notice**

If side access is not possible, proportionally more space is required for opening the access doors.

### 1.3 Roof frame

Roof frames are required for installing RoofVent® units in the roof. Please consider the following in the design process:

- The extract air grille and the access panels must be freely accessible under the roof.
- The roof frame must protrude at least 200 mm from the roof, so that no water can penetrate during a rainstorm or snowfall.



**Notice**

The connection module is available in 4 lengths for adapting to the local installation situation.

- The opening (dimension Z2) must be large enough to accommodate the below-roof unit.
- The condensate must be able to drain off freely.
- The roof frame must be flat and horizontal.
- Insulate the roof frame before installing the unit (thermal insulation).
- Please observe the minimum distances when designing the roof frame (see chapter 1.2).

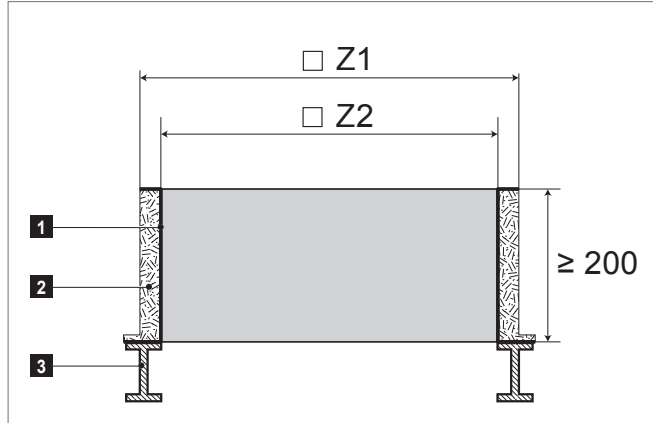

- 1 Weight-bearing inner wall of the roof frame
- 2 Thermal insulation
- 3 IPE beam

Z1	max.	mm	1460
Z2	min.	mm	1162
	max.	mm	1170

Table D2: Dimensions for roof frame

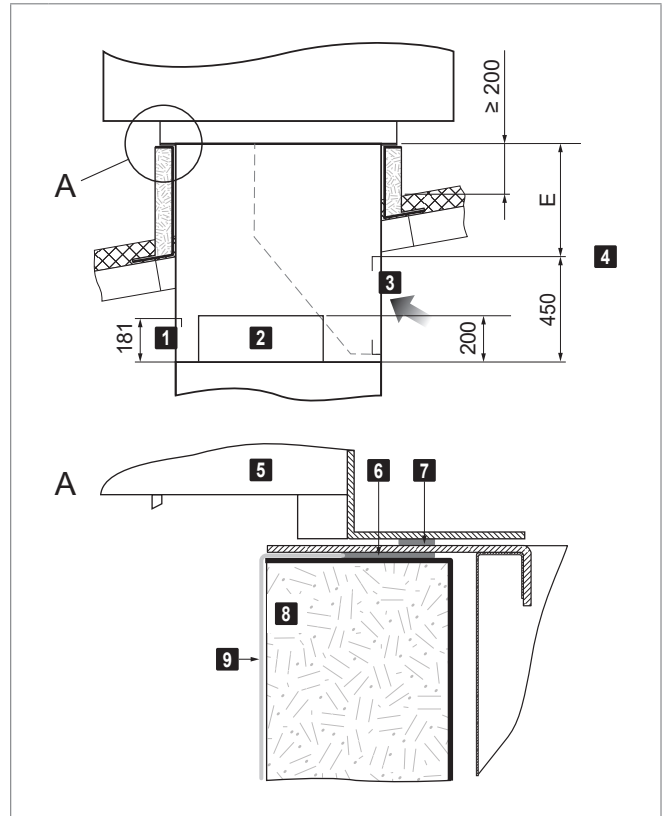

- 1 Access panel, connection box
- 2 Coil access panel (both sides)
- 3 Extract air grille
- 4 Dimension E see Table B12 auf Seite 19
- 5 Roof unit
- 6 Sealing compound (on site)
- 7 Sealing strip (fitted at the factory)
- 8 Roof frame
- 9 Membrane

Fig. D3: Installation of RoofVent® units in the roof frame (dimensions in mm)

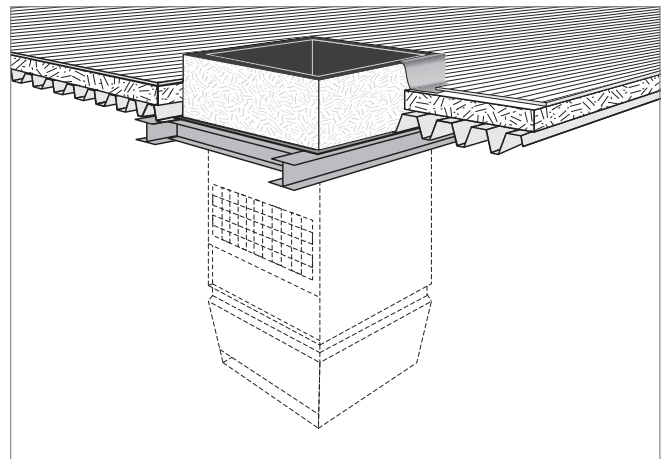

Fig. D4: Conceptual drawing of the roof frame

Depending on local conditions, 2 different types of roof frame can be used:

- Roof frame with straight side walls (where there is sufficient space)
- Roof frame with conical side walls (where a below-roof unit protruding into the room interferes with the cranes, for example)



### Notice

Ensure there is sufficient clearance for maintenance work (see chapter 1.2).

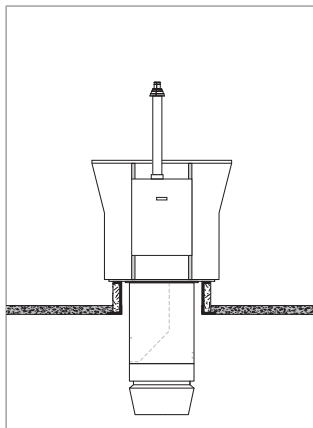

Fig. D5: Roof frame with straight side walls

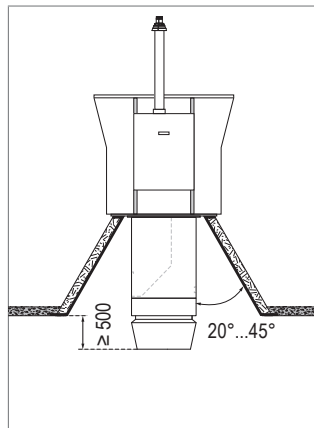

Fig. D6: Roof frame with conical side walls

## 1.4 Unit installation

Proceed as follows to position the unit:

### Below-roof unit

- Apply sealing compound to the roof frame.
- Screw in the transport eyes and attach the lifting gear.
- Transport the below-roof unit to the roof frame using a helicopter or crane.
- Turn the below-roof unit to the desired position.
- Hang the below-roof unit into the roof frame from above.

### Roof unit

- Remove the cover caps on the unit roof.
- Screw in the transport eyes and attach the lifting gear.
- Transport the roof unit to the roof, correctly position the roof unit over the below-roof unit and set it down.
- Screw the roof unit to the below-roof unit.
- Remove the transport eyes and refit the cover caps.

### Supply air/flue gas system

- Mount the loosely supplied system parts on the pre-installed first pipe section (plug-in connections with sealing ring and clamping band).
- Secure the plug-in connections against working loose inadvertently.

- Secure the system to the roof unit with the spacer and the fastening bracket.



Fig. D7: Fastening the flue gas line

## 1.5 Duct connection

If necessary, it is possible to connect an extract air duct to the below-roof unit instead of the extract air grille.

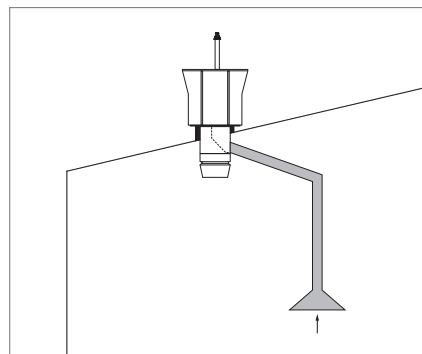

Fig. D8: Extract air duct

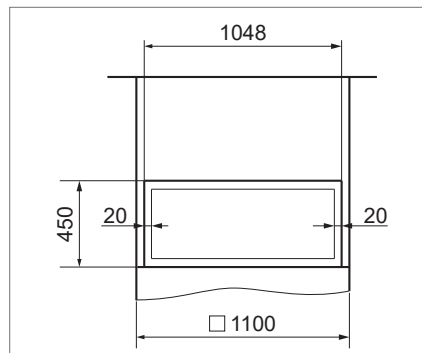

Fig. D9: Connection dimensions (in mm)

## 2 Hydraulic installation

### 2.1 Heating circuit

The complete heating circuit is already integrated in RoofVent® RG units. The following work must be carried out during installation:

- Connect the flow and return pipes of the below-roof unit to the connections in the roof unit using the metal tubes supplied loose.
- Fill the heating circuit with the supplied heat transfer fluid.

### 2.2 Condensate drain

The condensate from the gas condensing boiler is neutralised and flows off through the condensate drain on the underside of the gas boiler attachment.

- Install a condensate drain in accordance with the local provisions.
  - Plug connection: DN 40
- To avoid icing:
  - Run the condensate line through the roof into the building by the most direct route possible.
  - Insulate the outdoor part of the condensate line.

#### Condensate drain line with 'condensate drain inside' option

The condensate from the gas condensing boiler is channelled inside the RoofVent® unit to the drain connection in the connection module.

- Connect the drain hose of the roof unit with the drain hose of the below-roof unit and mount the drain connection in the connection module.
- Install a condensate drain in accordance with the local provisions.
  - Connection: External thread G ¾"

## 3 Gas connection



### Caution

Risk of injury from incorrect handling. The gas connection may only be carried out by specialists authorised by the gas supply company!

Please note the following:

- The fuel used is natural gas. Check the type of gas the unit is set to work with and, if necessary, have Hoval Customer Service reset the unit to the type of gas supplied locally.
- During operation of the unit, the required quantity of gas and the necessary pressure of gas must be present constantly.
  - Gas flow pressure: 17.4 – 50 mbar
- Connect the gas supply line with appropriate bolted joints which can be loosened, tension-free and vibration-free (gas hose, compensator).
- The connection of the unit to the gas supply line must be gas-tight.
- Install a gas shut-off valve in the gas supply line immediately upstream of the unit, as well as other components required by local regulations, such as gas filter, gas pressure regulator, pressure gauge with push-button tap, etc. (not included in the scope of delivery).

## 4 Electrical installation

- The electrical installation must only be carried out by a qualified electrician.
- Observe the relevant regulations (e.g. EN 60204-1).
- Choose the dimensions of the cable cross sections in line with the applicable regulations.
- Route signal and bus lines separately from mains cables.
- Make sure the lightning protection system for the units or for the entire building is planned and carried out by professionals.
- Provide overload protection equipment on site in the mains connection line of the zone control panel.
- Carry out the electrical installation according to the wiring diagram:
  - Power supply RoofVent®
  - Zone bus based on system layout
  - Signal lines
- Connect the connection box in the below-roof unit to the control block in the roof unit.
- Connect the electrical components of the below-roof unit to the connection box.

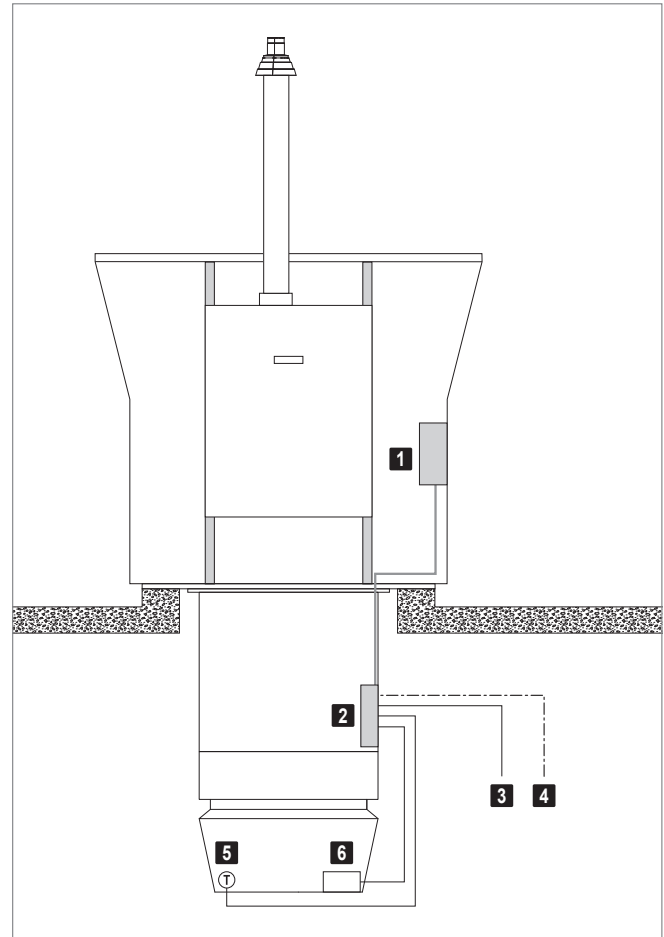

1 Control block

2 Connection box

3 Zone bus

4 Power supply RoofVent®

5 Supply air temperature sensor

6 Actuator Air-Injector

Fig. D10: On-site electrical connection

Component	Designation	Voltage	Cable	Comments	Start	Target
<b>TopTronic® C System control</b>	Power supply	3 × 400 VAC	NYM-J 5 × ... mm <sup>2</sup>		On-site	Zone control panel
		1 × 230 VAC	NYM-J 3 × ... mm <sup>2</sup>		On-site	Zone control panel
Zone control panel	Zone bus		J-Y(ST)Y 2 × 2 × 0.8 mm	max. 500 m length	Zone control panel	Hoval units
	System bus		Ethernet ≥ CAT 5	For connecting several zone control panels	Zone control panel	Further zone control panel
	Integration into the building management system		Ethernet ≥ CAT 5	BACnet, Modbus IP	Zone control panel	On-site (BMS)
			J-Y(ST)Y 2 × 2 × 0.8 mm	Modbus RTU	Zone control panel	On-site (BMS)
	Room temperature sensor		J-Y(ST)Y 2 × 2 × 0.8 mm	max. 250 m	Zone control panel	Sensors
	Additional room temperature sensors		J-Y(ST)Y 2 × 2 × 0.8 mm	max. 250 m	Zone control panel	Sensors
	Combination sensor room air quality, temperature and humidity		J-Y(ST)Y 4 × 2 × 0.8 mm	max. 250 m	Zone control panel	Sensors
	Fresh air temperature sensor		J-Y(ST)Y 2 × 2 × 0.8 mm	max. 250 m	Zone control panel	Sensors
	Combination sensor fresh air temperature and humidity		J-Y(ST)Y 2 × 2 × 0.8 mm	max. 250 m	Zone control panel	Sensors
	Collective alarm	Volt-free max. 230 VAC max. 24 VDC	NYM-O 2 × 1.5 mm <sup>2</sup>	max. 3 A max. 2 A	Zone control panel	On-site
	Power supply for units	3 × 400 VAC	NYM-J 5 × 4.0 mm <sup>2</sup> (min.)	RoofVent® units	Zone control panel	Hoval units
		3 × 400 VAC	NYM-J 5 × 1.5 mm <sup>2</sup> (min.)	TopVent® units	or on-site	
	System operator terminal (if external)	24 VDC	NYM-J 3 × 1.5 mm <sup>2</sup>	Power supply 0.42 A	Zone control panel	System operator terminal
			Ethernet ≥ CAT 5	Communication	Zone control panel	System operator terminal
	Zone operator terminal (if external)	24 VAC	J-Y(ST)Y 4 × 2 × 0.8 mm	Power supply, 1 A fusing, max. 250 m length	Zone control panel	Zone operator terminal
	External sensor values	0-10 VDC	J-Y(ST)Y 2 × 2 × 0.8 mm		On-site	Zone control panel
	External set values	0-10 VDC	J-Y(ST)Y 2 × 2 × 0.8 mm		On-site	Zone control panel
	Load shedding input	24 VAC	NYM-O 2 × 1.5 mm <sup>2</sup>	max. 1 A	On-site	Zone control panel
	Operating selector switch on terminal (analogue)	0-10 VDC	J-Y(ST)Y 2 × 2 × 0.8 mm		On-site (switch)	Zone control panel
	Operating selector switch on terminal (digital)	0-10 VDC	J-Y(ST)Y 6 × 2 × 0.8 mm		On-site (switch)	Zone control panel
Operating selector button on terminal	24 VAC	J-Y(ST)Y 6 × 2 × 0.8 mm		On-site (button)	Zone control panel	
Forced off	24 VAC	NYM-O 2 × 1.5 mm <sup>2</sup>	max. 1 A	On-site	Zone control panel	
<b>RoofVent® unit</b>	Power supply	3 × 400 VAC	NYM-J 5 × 4.0 mm <sup>2</sup> (min.)		Zone control panel or on-site	RoofVent® unit
	Zone bus		J-Y(ST)Y 2 × 2 × 0.8 mm	max. 500 m length	Zone control panel	RoofVent® unit
	Forced off	24 VAC	NYM-O 2 × 1.5 mm <sup>2</sup>	max. 1 A	On-site	RoofVent® unit
	Forced heating	24 VAC	NYM-O 2 × 1.5 mm <sup>2</sup>	max. 1 A	On-site	RoofVent® unit

Table D3: Cable list for on-site connections





---

**System design**

1 Design example. . . . . .40

2 Maintenance schedule . . . . . .42

3 Checklist for project discussions . . . . . .43

# 1 Design example



**Notice**

Use the 'HK-Select' program to design Hoval Indoor Climate Systems. You can download it free of charge on the Internet.

Design data	Example
<ul style="list-style-type: none"> <li>■ Hall geometry (L × W × H)</li> <li>■ Required fresh air flow rate</li> <li>■ Internal heat gains (machines, lighting, etc.)</li> <li>■ Heating with decentralised gas-fired heat generation</li> </ul>	<p>72 × 50 × 9 m                      44000 m<sup>3</sup>/h                      28 kW                      → Unit type RG</p>
<p>Design conditions heating:</p> <ul style="list-style-type: none"> <li>■ Fresh air temperature</li> <li>■ Room temperature</li> <li>■ Extract air conditions</li> <li>■ Fabric heat losses</li> </ul>	<p>– 15 °C                      18 °C                      20 °C / 40 %rh                      250 kW</p>
<p><b>Number of units</b></p> <ul style="list-style-type: none"> <li>■ Calculate the required number of units:  <math>n = \text{Fresh air flow rate} / \text{nominal air flow rate}</math></li> </ul>	<p><math>n = 44000 / 8000 = 5.5</math>                      → 6 units RG-9</p>
<p><b>Required heat output for coverage of fabric heat losses</b></p> <ul style="list-style-type: none"> <li>■ Calculate the required heat output for coverage of fabric heat losses per unit:  <math>Q_{H\_req} = (\text{fabric heat losses} - \text{internal heat loads}) / n</math></li> <li>■ Use the 'Hoval HK-Select' selection program to calculate the heat output for coverage of fabric heat losses under the given design conditions.</li> </ul>	<p><math>(250 - 28) / 6 = 37 \text{ kW per unit}</math>                      RG-9: 51.8 kW</p>
<p><b>Checks</b></p>	
<ul style="list-style-type: none"> <li>■ Effective air flow rate  <math>V_{eff} = \text{Nominal air flow rate} \times n</math></li> </ul>	<p><math>8000 \times 6 = 48000 \text{ m}^3/\text{h}</math>  <math>48000 \text{ m}^3/\text{h} &gt; 44000 \text{ m}^3/\text{h}</math>                      → OK</p>
<ul style="list-style-type: none"> <li>■ Effective heat output  <math>Q_{H\_effective} = \text{Output for coverage of fabric heat losses} \times n</math></li> </ul>	<p><math>51.8 \times 6 = 310.8 \text{ kW}</math>  <math>310.8 \text{ kW} &gt; (250 - 28) \text{ kW}</math>                      → OK</p>
<ul style="list-style-type: none"> <li>■ Mounting height                      Calculate the actual mounting height (= distance between the floor and the bottom edge of the unit) and compare with the minimum and maximum mounting height.  <math>Y = \text{Hall height} - \text{length of below-roof unit}</math></li> </ul>	<p><math>9000 - 1850 = 7150 \text{ mm}</math>  <math>Y_{min} = 5.0 \text{ m} &lt; 7.15 \text{ m}</math>                      → OK  <math>Y_{max} = 11.2 \text{ m} &gt; 7.15 \text{ m}</math>                      → OK</p>

<ul style="list-style-type: none"> <li>■ Floor area covered Compare the floor area covered with the base area of the hall (L × W). <math>A = \text{Floor area covered} \times n</math></li> </ul>	$797 \times 6 = 4782 \text{ m}^2$ $72 \times 50 = 3600 \text{ m}^2$ $4782 \text{ m}^2 > 3600 \text{ m}^2$ → OK
<ul style="list-style-type: none"> <li>■ Minimum and maximum clearances Determine the positioning of the units according to the number of units and the base area of the hall; check the minimum and maximum clearances.</li> </ul>	$n = 6 = 3 \times 2$ Unit clearance in length: $X = 72 / 3 = 24 \text{ m}$ $X_{\max} = 28 \geq 24 \text{ m}$ $X_{\min} = 13 \leq 24 \text{ m}$ → OK  Unit clearance in width: $X = 50 / 2 = 25 \text{ m}$ $X_{\max} = 28 \geq 25 \text{ m}$ $X_{\min} = 13 \leq 25 \text{ m}$ → OK



## 2 Maintenance schedule

Activity	Procedure	Interval
Clean unit	<ul style="list-style-type: none"> <li>■ Clean inside of RoofVent® unit with vacuum cleaner.</li> <li>■ Clean the heat exchanger and burner of the gas condensing boiler.</li> <li>■ Remove the siphon, clean it and rinse the condensate drain.</li> </ul>	1 × annually
Functional check	<ul style="list-style-type: none"> <li>■ Check function of the fan and actuators.</li> <li>■ Check function of the Air-Injector.</li> <li>■ Check the connections of the gas condensing boiler for leaks.</li> <li>■ Check ignition electrode and readjust or replace if necessary.</li> <li>■ Check function of the control system.</li> </ul>	1 × annually
Flue gas path test	<ul style="list-style-type: none"> <li>■ Check flue gas pipe and, if required, clean inside.</li> </ul>	1 × annually
Emission measurement	<ul style="list-style-type: none"> <li>■ Check setting of the gas control valve and readjust where necessary.</li> </ul>	1 × annually
Neutraliser	<ul style="list-style-type: none"> <li>■ Loosen contaminated granulate and clean neutralisation unit with water.</li> <li>■ Replace heavily soiled granulate.</li> </ul>	1 × annually
Check of the heat transfer fluid	<ul style="list-style-type: none"> <li>■ Check the system pressure and top up with heat transfer fluid if necessary.</li> <li>■ Take sample and test:                             <ul style="list-style-type: none"> <li>– Test pH value with indicator strips</li> <li>– Test frost protection with a refractometer</li> </ul> </li> </ul>	1 × annually
Filter change	<ul style="list-style-type: none"> <li>■ Renew air filter.</li> </ul>	When the filter alarm is displayed, at least 1× annually
Test of the inhibitor protection	<ul style="list-style-type: none"> <li>■ Take a sample of the heat transfer fluid and have the inhibitor protection analysed by a suitable service provider.</li> </ul>	Every 3 years

Table E1: Maintenance schedule

Project

Project No.

Date

Name

Function

Address

Tel.

Fax

E-mail

**Information about the hall**

Application

Type

Insulation

Length

Width

Height

Is the roof strong enough?

yes  no

Are there window areas?

yes  no

Percentage?

Is there a crane?

yes  no

Height?

Is there enough space for installation and servicing?

yes  no

Are there any voluminous installations or machines?

yes  no

Are pollutants present?

yes  no

Which?

– If yes, are they heavier than air?

yes  no

Is oil contained in the extract air?

yes  no

Is dust present?

yes  no

Dust level?

Is there high humidity?

yes  no

How much?

Is the air volume balanced?

yes  no

Are local machine extractions required?

yes  no

Are any conditions imposed by public authorities?

yes  no

Which?

Are sound level requirements to be fulfilled?

yes  no

Which?

### Design data

Fresh air flow rate?	<input type="text"/>	m <sup>3</sup> /h
Fresh air / hall area	<input type="text"/>	m <sup>3</sup> /h per m <sup>2</sup>
Air change rate	<input type="text"/>	
Internal heat gains (machines, ...)	<input type="text"/>	kW
Heating and cooling	<input type="text"/>	
Hydraulic system	<input type="text"/>	
Unit size	<input type="text"/>	
Control zones	<input type="text"/>	

### Design conditions heating

■ Highest outside temperature and humidity	<input type="text"/>	°C	<input type="text"/>	%
■ Room temperature	<input type="text"/>	°C		
■ Extract air temperature and humidity	<input type="text"/>	°C	<input type="text"/>	%
■ Fabric heat losses	<input type="text"/>	kW		
■ Temperature of the heating medium	<input type="text"/>	/	<input type="text"/>	°C

### Design conditions cooling

■ Highest outside temperature and humidity	<input type="text"/>	°C	<input type="text"/>	%
■ Room temperature	<input type="text"/>	°C		
■ Extract air temperature and humidity	<input type="text"/>	°C	<input type="text"/>	%
■ Transmission sensible gains	<input type="text"/>	kW		
■ Temperature of the cooling medium	<input type="text"/>	/	<input type="text"/>	°C

### Further information



## Hoval quality. You can count on us.

As a specialist in heating and climate technology, Hoval is your experienced partner for system solutions. For example, you can heat water with the sun's energy and your rooms with oil, gas, wood or a heat pump. Hoval ties together the various technologies and also integrates room ventilation into the system. So you can save energy while looking after the environment and your costs – and still enjoy the same level of comfort.

Hoval is one of the leading international companies for indoor climate solutions. More than 75 years of experience continuously motivate us to design innovative system solutions. We manufacture complete systems for heating, cooling and ventilation to more than 50 countries.

We take our responsibility for the environment seriously. Energy efficiency is at the heart of the heating and ventilation systems we design and develop.

## Responsibility for energy and environment

### United Kingdom

Hoval Ltd.  
Northgate, Newark  
Nottinghamshire  
NG24 1JN  
hoval.co.uk

Your Hoval partner