





Hoval RoofVent[®] RP

Design handbook

Supply and extract air handling units with efficient air distribution for heating and cooling with decentralised Belaria[®] VRF heat pump

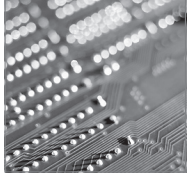

	<p>Hoval Indoor Climate Systems 3</p> <p>Efficient. Flexible. Reliable.</p>	<p>A</p>
	<p>RoofVent® RP 7</p> <p>Supply and extract air handling units with efficient air distribution for heating and cooling spaces up to 25 m in height with decentralised heat pump</p>	<p>B</p>
	<p>Options 33</p>	<p>C</p>
	<p>Transport and installation 41</p>	<p>D</p>
	<p>System design 55</p>	<p>E</p>
	<p>Control systems</p> <p>Hoval TopTronic® C → see 'Control Systems for Hoval Indoor Climate Systems' manual</p>	<p></p>



Hoval Indoor Climate Systems

Efficient. Flexible. Reliable.

A





Efficient. Flexible. Reliable.

Hoval indoor climate systems are decentralised systems for heating, cooling and ventilating halls for industrial, commercial and leisure applications. The systems have a modular structure. One system comprises several ventilation units which are spread around the room. These units are equipped with reversible heat pumps and gas-fired appliances for decentralised heat and cold generation, or they heat and cool with a connection to a central energy supply. Tailored control systems complete the system and ensure the effective combination and optimal use of all resources.

Diverse range of units ensures flexibility

Different types of ventilation units can be combined to create the perfect system for the project in question:

- RoofVent® supply and extract air handling units
- TopVent® supply air units
- TopVent® recirculation units

The number of supply and extract air handling units depends on how much fresh air is required in order to create a comfortable atmosphere for people in the building. Recirculation units cover additional heat or cool demand as required. A broad range of unit types and sizes with heating and cooling coils in various output levels means that the overall output of the system can be scaled to whatever level is required.

Specially designed unit versions are also available for halls with particularly humid or oily extract air.

Furthermore, there is a range of units available which have been expressly developed for very specific purposes. ProcessVent units, for example, are coupled with extract air purification systems in industrial halls and recover heat from process air.

Draught-free air distribution

A key feature of Hoval indoor climate units is the patented vortex air distributor, known as the Air-Injector. It is controlled automatically and changes the blowing angle of the air continuously between vertical and horizontal. The highly efficient air supply system has many advantages:

- It provides a high level of comfort during heating and cooling. No draughts develop in the hall.
- The efficient and even air distribution ensures that the indoor climate units cover a large area.
- The Air-Injector keeps the temperature stratification in the room low, thus minimising heat loss through the roof.

Control with specialist expertise

The TopTronic® C control system, which was specifically developed for Hoval indoor climate systems, regulates the separate units individually and controls them based on zones. This enables optimal adjustment to the local requirements of the different usage areas in the building. The patented control algorithm optimises energy use and ensures maximum comfort and hygiene levels. Clear interfaces make it easy to connect the system to the building management system.

Simpler control systems are also available for units that are only used for supply air or air recirculation.

Competent and reliable

Hoval will support you and provide expert knowledge throughout all project phases. You can rely on comprehensive technical advice when it comes to planning Hoval indoor climate systems and on the skills of the Hoval technicians during the installation, commissioning and maintenance of the system.

System with decentralised heat and cold generation with heat pump

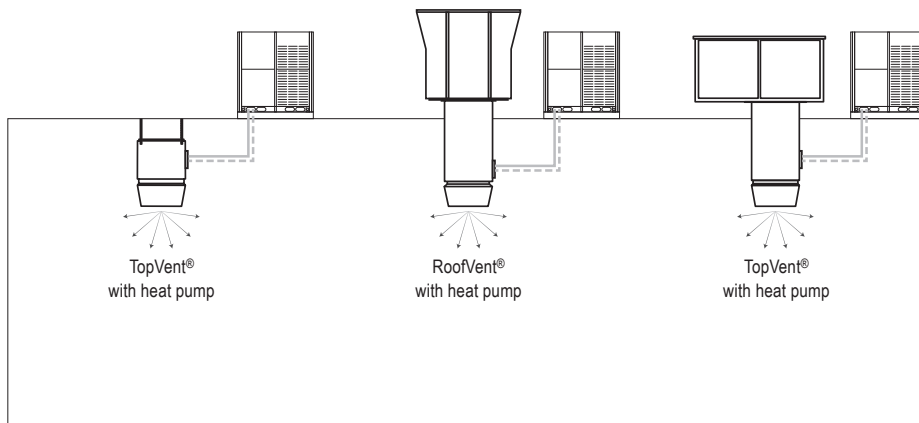

System with central heat and cold generation

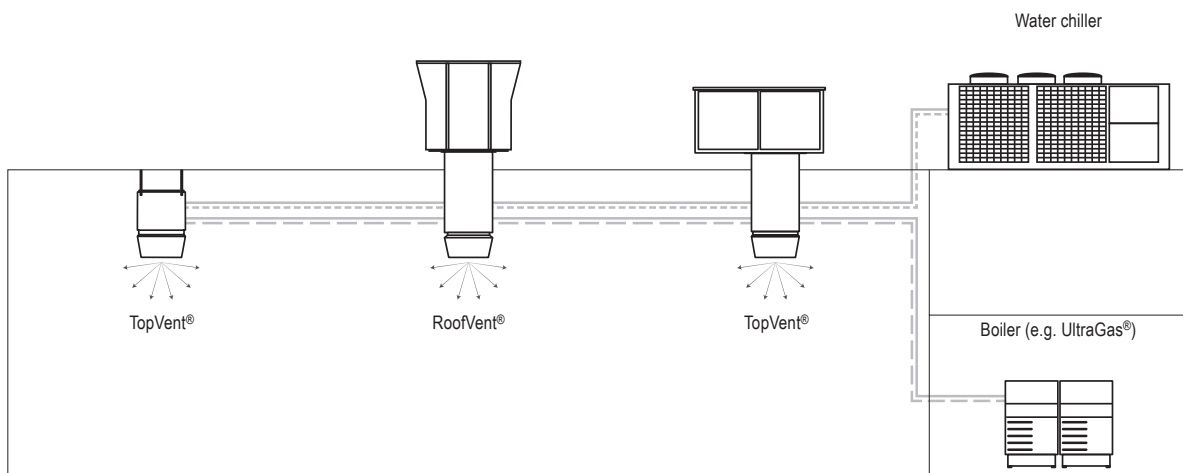

System with decentralised, gas-fired heat generation

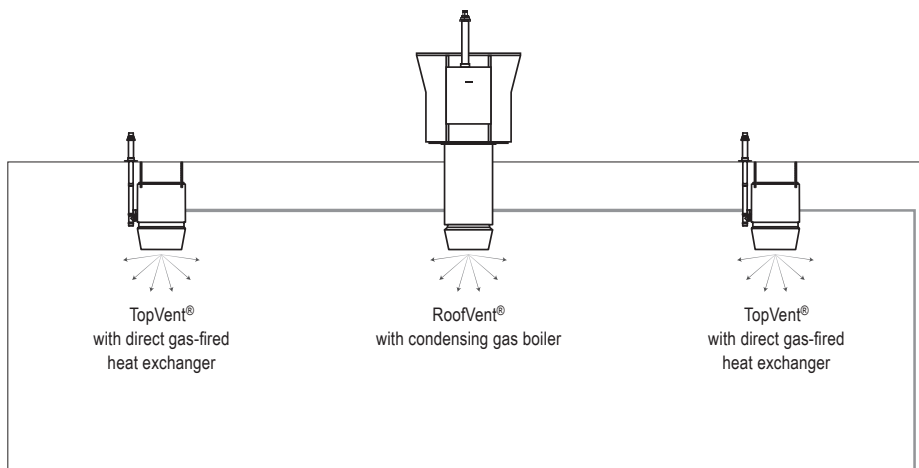



RoofVent® RP

Supply and extract air handling units with efficient air distribution for heating and cooling spaces up to 25 m in height with decentralised heat pump

1 Use	8
2 Construction and operation	8
3 Technical data	16
4 Specification texts	28

B

1 Use

1.1 Intended use

RoofVent® RP units are supply and extract air handling units for heating and cooling spaces up to 25 m in height with decentralised heat pump. They have the following functions:

- Fresh air supply
- Extract air removal
- Heating and cooling with heat pump
- Energy recovery with highly efficient plate heat exchanger
- Filtering of the fresh air and the extract air
- Air distribution and destratification with adjustable Air-Injector

The RoofVent® RP unit complies with all the requirements of the Ecodesign Directive 2009/125/EC relating to environmentally friendly design of ventilation systems. It is a system of the 'non-residential ventilation unit' (NRVU) and 'bidirectional ventilation unit' (BVU) type, provided for in Commission Regulation (EU) 1253/2014.

The Hoval TopTronic® C integrated control system ensures energy-efficient, demand-based operation of Hoval indoor climate systems.

Intended use also includes compliance with the operating instructions. Any usage over and above this use is considered to be not as intended. The manufacturer can accept no liability for damage resulting from improper use.

1.2 User group

The units are only allowed to be installed, operated and maintained by authorised and instructed personnel who are well acquainted with the units and are informed about possible dangers.

2 Construction and operation

RoofVent® RP units consist of the following components:

Roof unit with energy recovery

The self-supporting housing for mounting on the roof frame is of double-shell construction; this ensures good thermal insulation and high stability. The roof unit includes:

- the fans
- the air filters
- the plate heat exchanger with control dampers
- the control block

All components are easily accessible for maintenance work through large access openings.

Below-roof unit

The below-roof unit comprises the following components:

- Connection module:
 - The connection module serves as an air duct through the roof and for drawing in extract air from the hall through the extract air grille. To enable easy adaptation to local installation conditions, the connection module is available in 4 lengths. It also contains the electrical connection box of the below-roof unit. This has a direct plug connection to the control block in the roof unit via the wiring harness.
- Heating/cooling section
 - The heating cooling section contains the following components:
 - Heating/cooling coil for heating and cooling the supply air
 - Condensate separator
- Air-Injector
 - The Air-Injector is a patented, infinitely variable vortex air distributor for the draught-free introduction of air into the hall under changing operating conditions.

Heat pump system

The reversible air/air heat pump system in split design generates both heat and cold decentrally. It consists of the following components:

- Belaria® VRF heat pump with continuously modulating inverter technology for precise output control and high efficiency
- Conversion board for communication between heat pump, expansion valve and indoor climate unit (mounted in the roof unit)
- Expansion valve (mounted in the combi box)

The combi box is supplied loose for on-site installation on the below-roof unit.

RoofVent® RP units are available in 2 unit sizes and a total of 3 output levels:

Unit size	Heat pump	Conversion board and expansion valve
RP-6	Belaria® VRF (33)	1 ×
	Belaria® VRF (40)	1 ×
RP-9	Belaria® VRF (67)	2 ×

Table B1: Availability

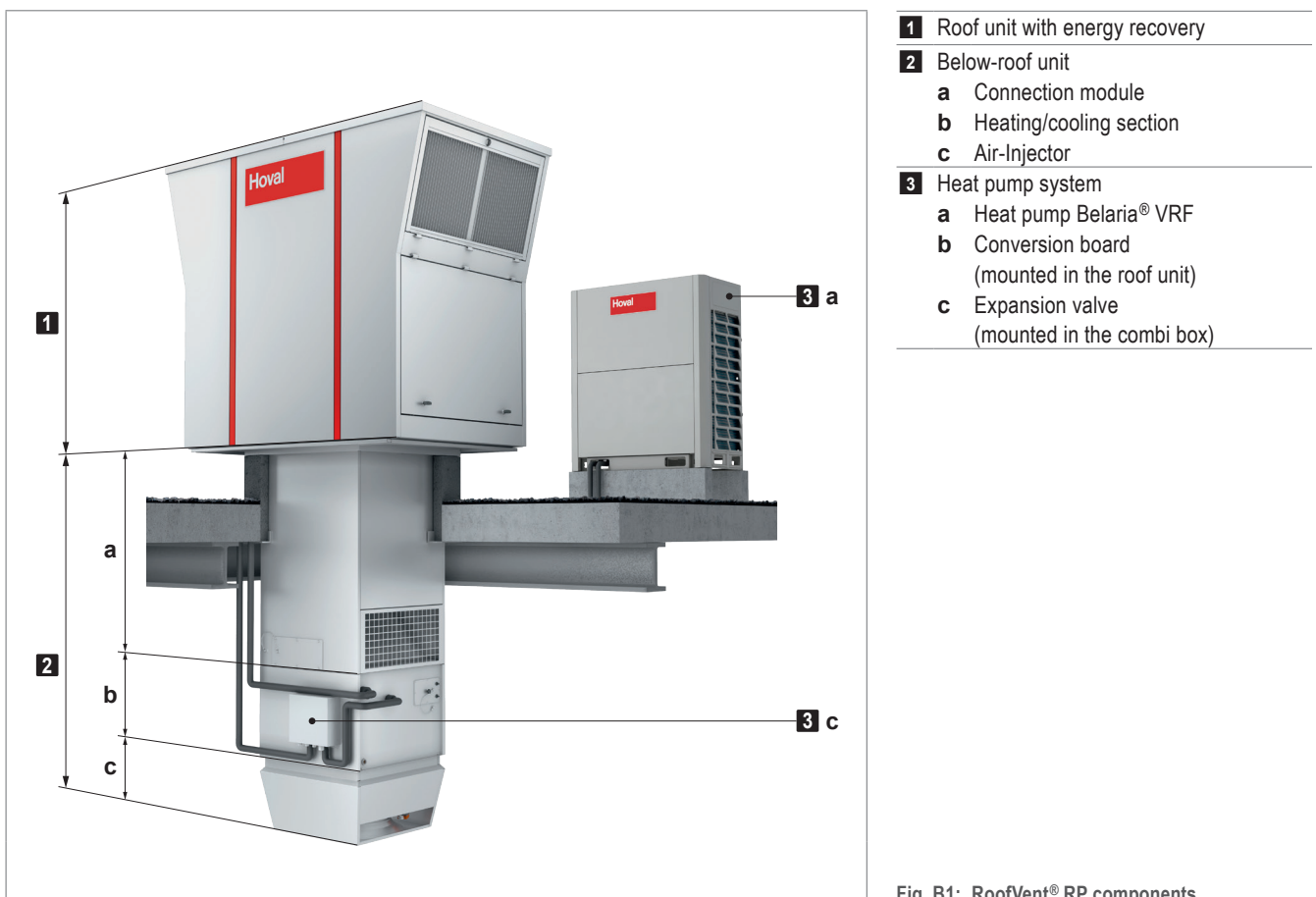
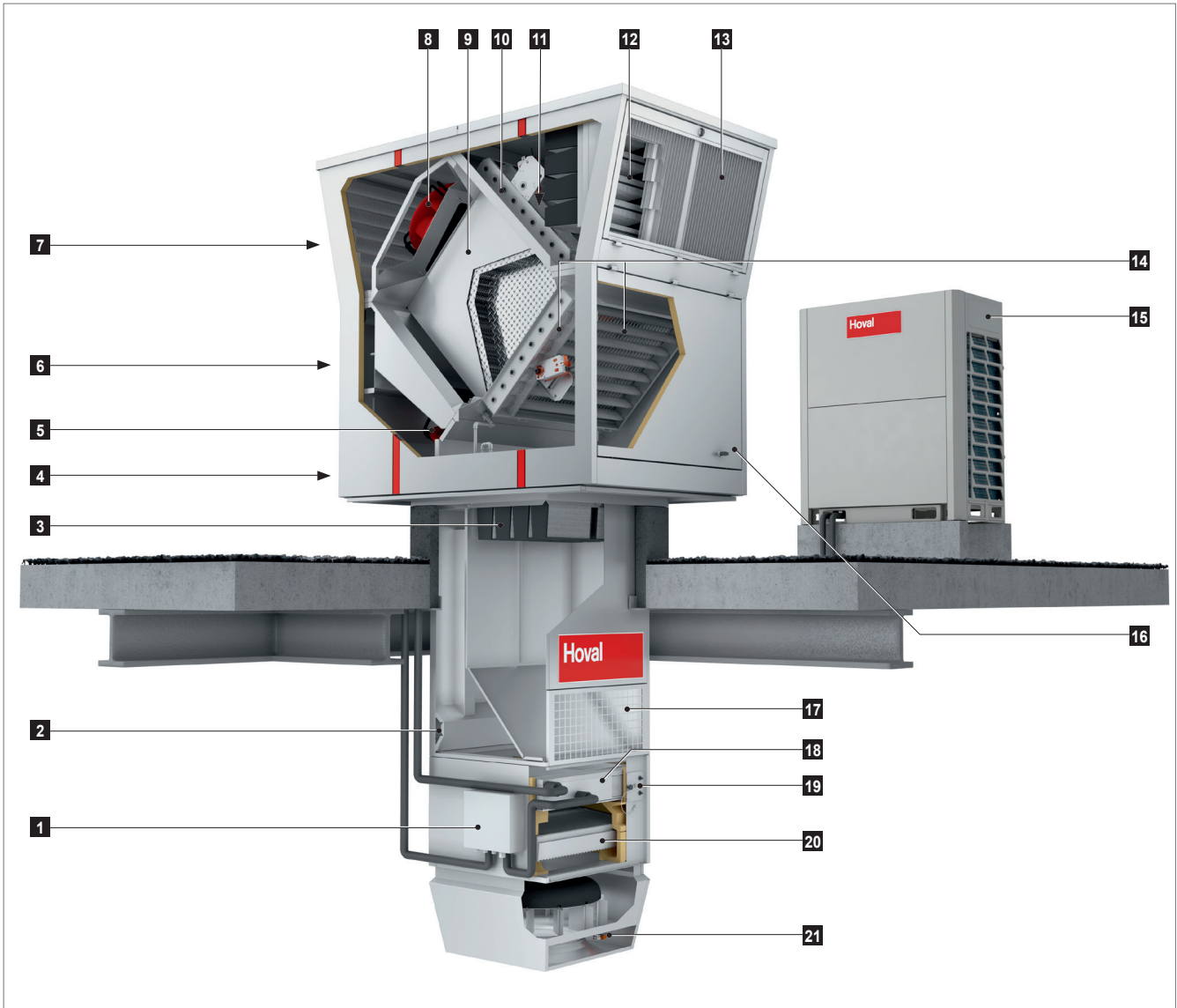

Fig. B1: RoofVent® RP components

2.1 Construction and operation RoofVent® RP-6



- | | |
|--|---|
| 1 Combi box with expansion valve | 11 Fresh air damper with actuator |
| 2 Connection box | 12 Fresh air filter |
| 3 Extract air filter | 13 Fresh air access door |
| 4 Supply air access door | 14 Extract air and recirculation dampers with actuator |
| 5 Supply air fan | 15 Heat pump Belaria® VRF (33, 40) |
| 6 Control block with conversion board | 16 Extract air access door |
| 7 Exhaust air access door | 17 Extract air grille |
| 8 Exhaust air fan | 18 Heating/cooling coil |
| 9 Plate heat exchanger with bypass
(for performance control and as recirculation bypass) | 19 Access panel, liquid temperature sensor |
| 10 Bypass damper with actuator | 20 Condensate separator |
| | 21 Actuator Air-Injector |

Fig. B2: Construction RoofVent® RP-6

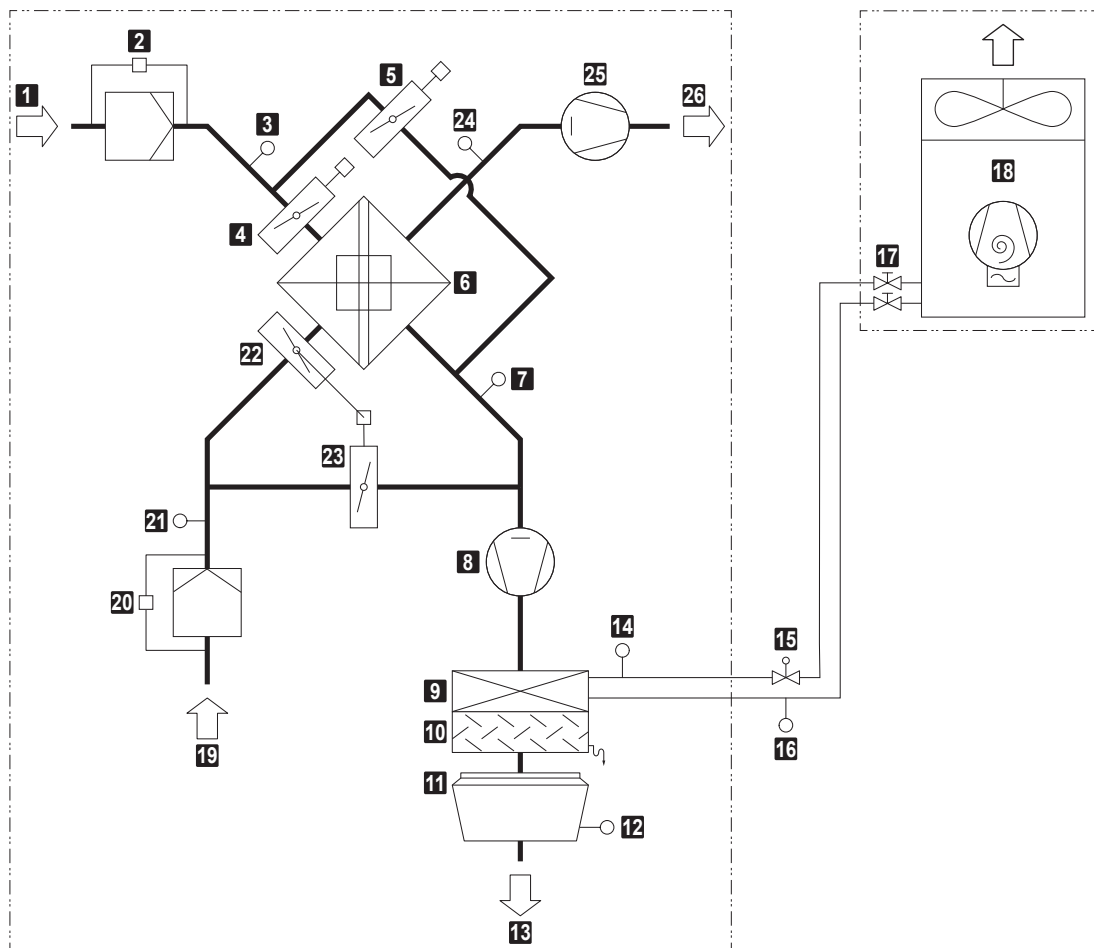

1 Fresh air	14 Liquid temperature sensor
2 Fresh air filter with differential pressure switch	15 Expansion valve (supplied loose)
3 Temperature sensor air inlet ER (optional)	16 Gas temperature sensor (supplied loose)
4 Fresh air damper with actuator	17 Shut-off valves
5 Bypass damper with actuator	18 Heat pump Belaria® VRF (33, 40)
6 Plate heat exchanger	19 Extract air
7 Temperature sensor air outlet ER (optional)	20 Extract air filter with differential pressure switch
8 Supply air fan with flow rate monitoring	21 Extract air temperature sensor
9 Heating/cooling coil	22 Extract air damper with actuator
10 Condensate separator	23 Recirculation damper (opposed to the extract air damper)
11 Air-Injector with actuator	24 Exhaust air temperature sensor
12 Supply air temperature sensor	25 Exhaust air fan with flow rate monitoring
13 Supply air	26 Exhaust air

Table B2: Function diagram RoofVent® RP-6

2.2 Construction and operation RoofVent® RP-9

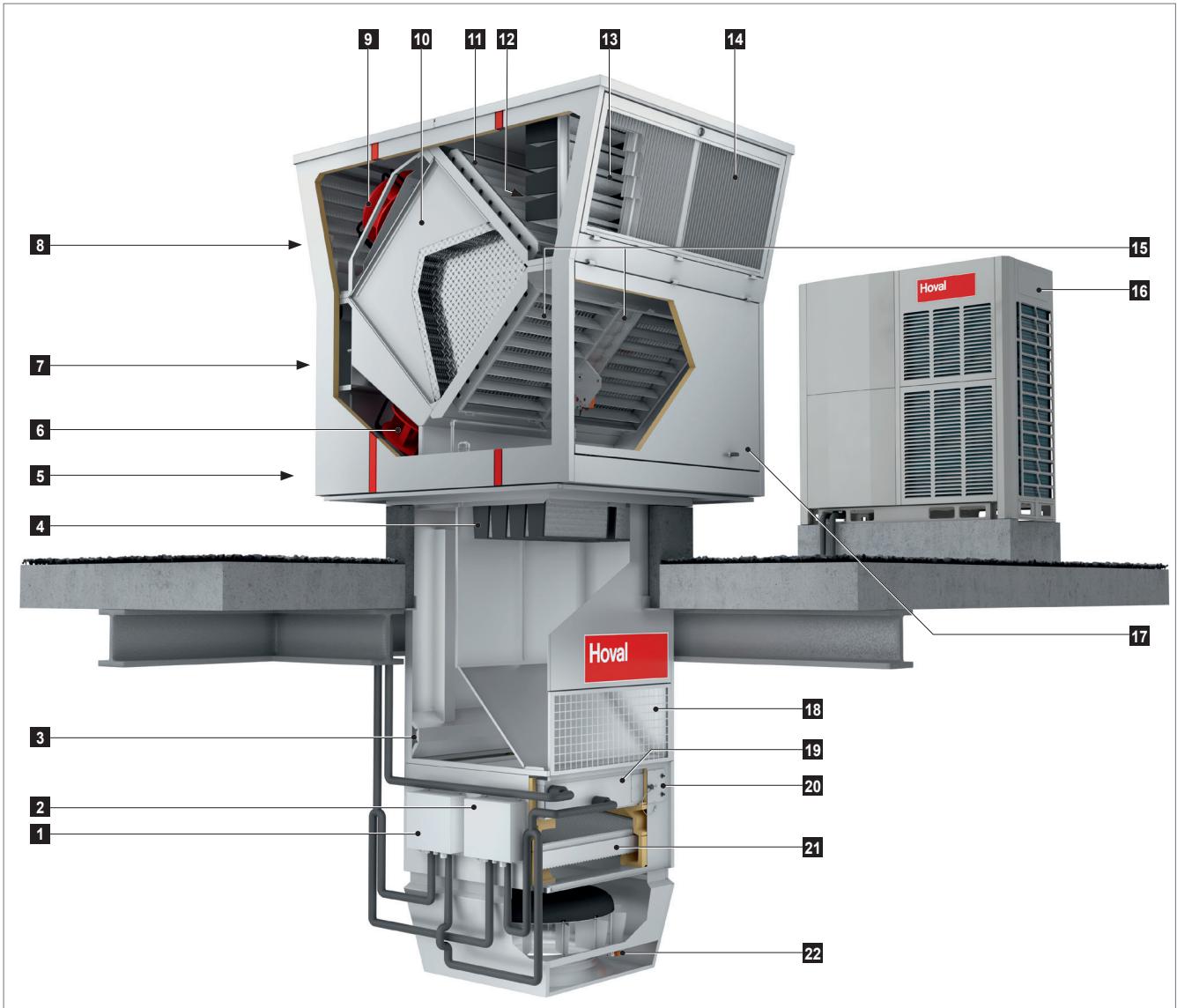

- | | |
|---|---|
| 1 Combi box VRF 02 with expansion valve | 12 Bypass damper with actuator |
| 2 Combi box VRF 03 with expansion valve | 13 Fresh air filter |
| 3 Connection box | 14 Fresh air access door |
| 4 Extract air filter | 15 Extract air and recirculation dampers with actuator |
| 5 Supply air access door | 16 Heat pump Belaria® VRF (67) |
| 6 Supply air fan | 17 Extract air access door |
| 7 Control block with conversion boards | 18 Extract air grille |
| 8 Exhaust air access door | 19 Heating/cooling coil |
| 9 Exhaust air fan | 20 Access panel, liquid temperature sensor |
| 10 Plate heat exchanger with bypass
(for performance control and as recirculation bypass) | 21 Condensate separator |
| 11 Fresh air damper with actuator | 22 Actuator Air-Injector |

Fig. B3: Construction RoofVent® RP-9

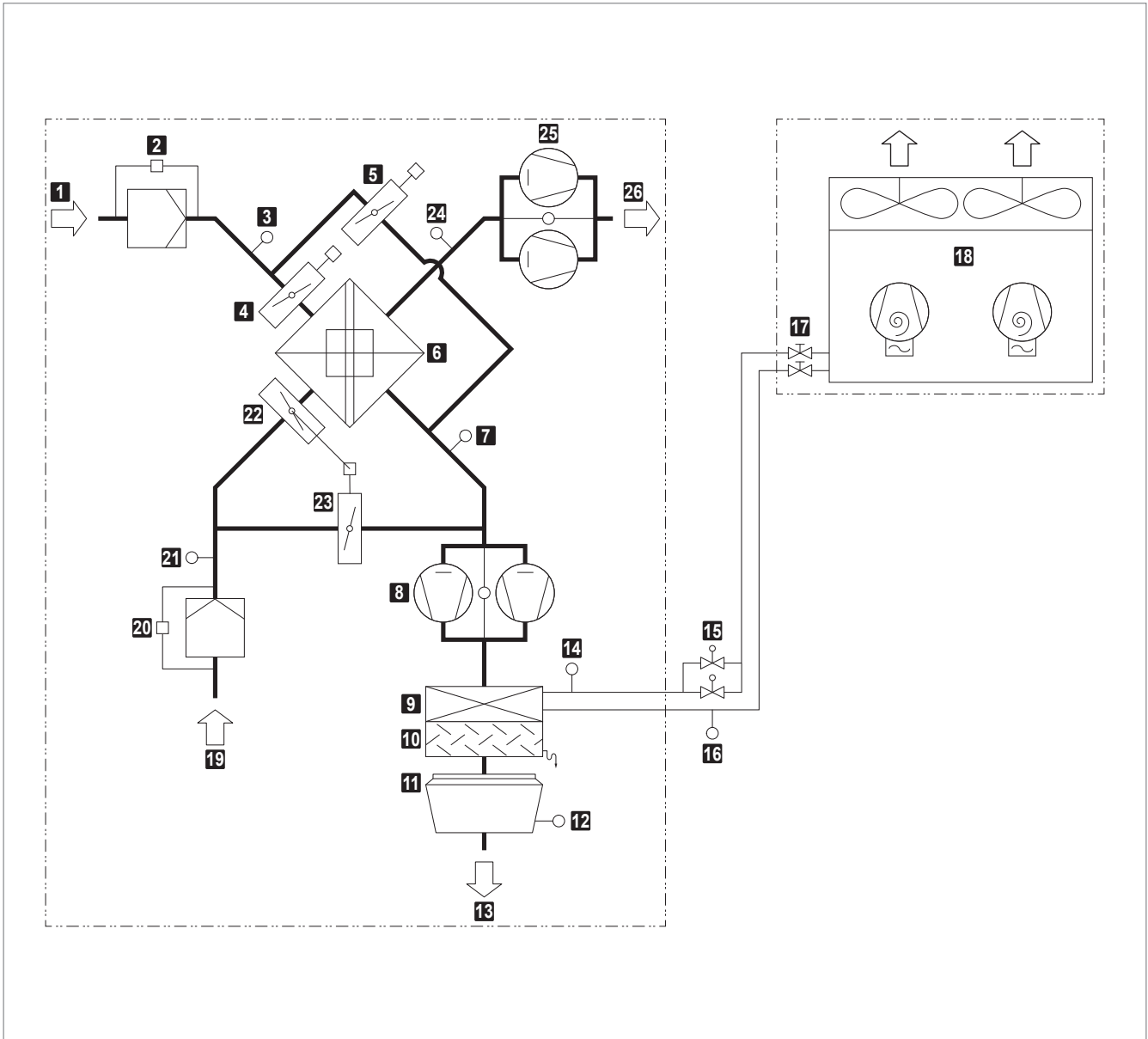

1 Fresh air	14 Liquid temperature sensor
2 Fresh air filter with differential pressure switch	15 Expansion valves (supplied loose)
3 Temperature sensor air inlet ER (optional)	16 Gas temperature sensor (supplied loose)
4 Fresh air damper with actuator	17 Shut-off valves
5 Bypass damper with actuator	18 Heat pump Belaria® VRF (67)
6 Plate heat exchanger	19 Extract air
7 Temperature sensor air outlet ER (optional)	20 Extract air filter with differential pressure switch
8 Supply air fans with flow rate monitoring	21 Extract air temperature sensor
9 Heating/cooling coil	22 Extract air damper with actuator
10 Condensate separator	23 Recirculation damper (opposed to the extract air damper)
11 Air-Injector with actuator	24 Exhaust air temperature sensor
12 Supply air temperature sensor	25 Exhaust air fans with flow rate monitoring
13 Supply air	26 Exhaust air

Table B3: Function diagram RoofVent® RP-6

2.3 Operating modes

The RoofVent® RP has the following operating modes:

- Ventilation
- Ventilation (reduced)
- Air quality
- Recirculation
- Exhaust air
- Supply air
- Standby

The TopTronic® C control system regulates these operating modes automatically for each control zone in accordance

with the specifications in the calendar. The following points also apply:

- The operating mode of a control zone can be switched over manually.
- Each RoofVent® unit can operate individually in a local operating mode: Off, Recirculation, Supply air, Exhaust air, Ventilation.

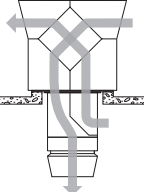
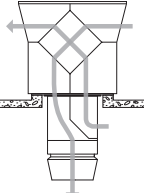
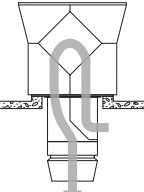
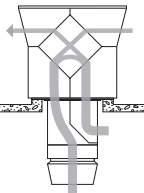
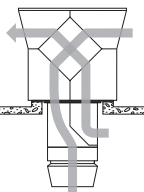
Code	Operating mode		Description
VE	<p>Ventilation</p> <p>The unit blows fresh air into the room and exhausts polluted room air. The room temperature set value day is active. Depending on the temperature conditions, the system continuously controls:</p> <ul style="list-style-type: none"> ■ the energy recovery ■ the heating/cooling 		<p>Supply air fan on ¹⁾</p> <p>Exhaust air fan on ¹⁾</p> <p>Energy recovery 0-100 %</p> <p>Extract air damper open</p> <p>Recirculation damper closed</p> <p>Heating/cooling 0-100 %</p> <p>¹⁾ Adjustable flow rate</p>
VEL	<p>Ventilation (reduced)</p> <p>As VE, but the unit only operates with the set minimum values for the supply and exhaust air volumes</p>		<p>Supply air fan MIN</p> <p>Exhaust air fan MIN</p> <p>Energy recovery 0-100 %</p> <p>Extract air damper open</p> <p>Recirculation damper closed</p> <p>Heating/cooling 0-100 %</p>
AQ	<p>Air quality</p> <p>This is the operating mode for demand-controlled ventilation of the room. The room temperature set value day is active. Depending on the temperature conditions, the system continuously controls:</p> <ul style="list-style-type: none"> ■ the energy recovery ■ the heating/cooling <p>Depending on the room air quality or room air humidity, the system operates in one of the following operating states:</p>		
AQ_REC	<ul style="list-style-type: none"> ■ Air quality Recirculation: <p>When air quality is good and air humidity appropriate, the unit heats or cools in recirculation operation.</p>		Like REC
AQ_ECO	<ul style="list-style-type: none"> ■ Air quality Mixed air: <p>When ventilation requirements are medium, the unit heats or cools in mixed air operation. The supply and exhaust air volume is based on the air quality.</p>		<p>Supply air fan MIN-MAX</p> <p>Exhaust air fan MIN-MAX</p> <p>Energy recovery 0-100 %</p> <p>Extract air damper 50 %</p> <p>Recirculation damper 50 %</p> <p>Heating/cooling 0-100 %</p>
AQ_VE	<ul style="list-style-type: none"> ■ Air quality Ventilation: <p>When ventilation requirements are high or the room air humidity is too high, the unit heats or cools in pure ventilation operation. The supply and exhaust air volume is based on the air quality.</p>		<p>Supply air fan MIN-MAX</p> <p>Exhaust air fan MIN-MAX</p> <p>Energy recovery 0-100 %</p> <p>Extract air damper open</p> <p>Recirculation damper closed</p> <p>Heating/cooling 0-100 %</p>

<p>REC</p>	<p>Recirculation On/Off recirculation operation with TempTronic algorithm: During heat or cool demand, the unit draws in room air, heats or cools it and blows it back into the room. The room temperature set value day is active. The flow rate is controlled in 2 stages.</p>		<p>Supply air fan 0 / MIN / MAX ¹⁾ Exhaust air fan off Energy recovery 0 % Extract air damper closed Recirculation damper open Heating/cooling on ¹⁾</p>
<p>DES</p>	<ul style="list-style-type: none"> ■ De-stratification: To avoid heat build-up under the ceiling, it may be appropriate to switch on the fan when there is no heat demand (either in permanent operation or in on/off operation depending on the temperature stratification, as desired). 		<p>¹⁾ Depending on heat or cool demand</p>
<p>EA</p>	<p>Exhaust air The unit extracts spent room air. There is no room temperature control. Unfiltered fresh air enters the room through open windows and doors or another system provides air supply.</p>		<p>Supply air fan off Exhaust air fan on ¹⁾ Energy recovery 0 % Extract air damper open Recirculation damper closed Heating/cooling off</p> <p>¹⁾ Adjustable flow rate</p>
<p>SA</p>	<p>Supply air The unit blows fresh air into the room. The room temperature set value day is active. Depending on the temperature conditions, the system controls the heating/cooling. Spent room air passes through open windows and doors or another system provides extraction.</p>		<p>Supply air fan on ¹⁾ Exhaust air fan off Energy recovery 0 % ²⁾ Extract air damper open Recirculation damper closed Heating/cooling 0-100 %</p> <p>¹⁾ Adjustable flow rate ²⁾ Fresh air and bypass dampers are open</p>
<p>ST</p>	<p>Standby The unit is ready for operation. The following operating modes are activated if required:</p>		
<p>CPR</p>	<ul style="list-style-type: none"> ■ Cooling protection: If the room temperature drops below the set value for cooling protection, the unit heats up the room in recirculation operation. 		<p>Supply air fan MAX Exhaust air fan off Energy recovery 0 % Extract air damper closed Recirculation damper open Heating/cooling on</p>
<p>OPR</p>	<ul style="list-style-type: none"> ■ Overheating protection: If the room temperature rises above the set value for overheating protection, the unit cools down the room in recirculation operation. If the temperatures also permit fresh air cooling, the unit automatically switches to night cooling (NCS) to save energy. 		<p>Supply air fan on ¹⁾ Exhaust air fan on ¹⁾ Energy recovery 0 % Extract air damper open Recirculation damper closed Heating/cooling off</p> <p>¹⁾ Adjustable flow rate</p>
<p>NCS</p>	<ul style="list-style-type: none"> ■ Night cooling: If the room temperature exceeds the set value for night cooling and the current fresh air temperature permits it, the unit blows cool fresh air into the room and extracts warmer room air. 		<p>Supply air fan on ¹⁾ Exhaust air fan on ¹⁾ Energy recovery 0 % Extract air damper open Recirculation damper closed Heating/cooling off</p> <p>¹⁾ Adjustable flow rate</p>
<p>L_OFF</p>	<p>Off (local operating mode) The unit is switched off. Frost protection remains active.</p>		<p>Supply air fan off Exhaust air fan off Energy recovery 0 % Extract air damper closed Recirculation damper open Heating/cooling off</p>

Table B4: RoofVent® RP operating modes

3 Technical data

3.1 Type code

	RP - 6 - J ...
Unit type	RP
RoofVent® RP	
Unit size	6 or 9
Heating/cooling section	J with coil type J for Belaria® VRF (33) L with coil type L for Belaria® VRF (40) N with coil type N for Belaria® VRF (67)
Further options	

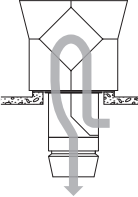
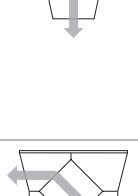
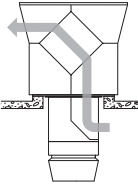
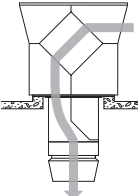
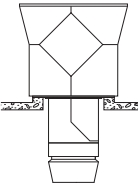
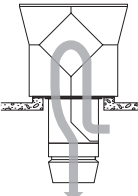
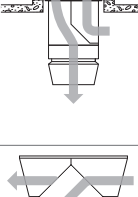
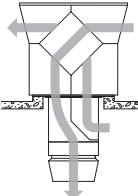
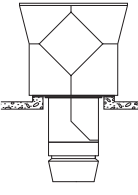
Table B5: Type code

3.2 Application limits

Fresh air temperature heating mode	min.	°C	-25	
	max.	°C	24	
Fresh air temperature cooling mode	min.	°C	-15	
	max.	°C	48	
Extract air temperature	max.	°C	45	
Moisture content of extract air ¹⁾	max.	g/kg	15	
Supply air temperature	max.	°C	45	
Room temperature setpoint	min.	°C	15	
Air flow rate	Size 6:	min.	m³/h	3100
	Size 9:	min.	m³/h	5000
Condensate quantity	Size 6:	max.	kg/h	90
	Size 9:	max.	kg/h	150
The units cannot be used in:				
■ Damp locations				
■ Rooms with mineral oil vapours in the air				
■ Rooms with a high salt content in the air				
■ Rooms with acidic or alkaline vapours in the air				
¹⁾ Units for applications where the humidity in the room increases by more than 2 g/kg are available on request.				

Table B6: Application limits

3.3 Electrical connection

RoofVent® RP

Unit type		RP-6	RP-9
Supply voltage	V AC	3 × 400	3 × 400
Permitted voltage tolerance	%	± 5	± 5
Frequency	Hz	50	50
Connected load	kW	4.3	8.4
Current consumption max.	A	7.1	14.1
Series fuse	A	13.0	20.0

Table B7: RoofVent® RP electrical connections

Heat pump Belaria® VRF

Heat pump Belaria®		VRF (33)	VRF (40)	VRF (67)
Supply voltage	V AC	3 × 400	3 × 400	3 × 400
Permitted voltage tolerance	%	± 2	± 2	± 2
Frequency	Hz	50	50	50
Connected load	kW	16.5	20.6	34.0
Current consumption max.	A	26.4	33.1	54.5
Series fuse	A	32.0	40.0	63.0
Inrush current	A	–	–	–

Table B8: Electrical connection Belaria® VRF

3.4 Air flow rate

Unit type		RP-6	RP-9
Nominal air flow rate	m ³ /h	5500	8000
Floor area covered	m ²	480	797

Table B9: Air flow rate

3.5 Air filtration

Filter	Fresh air	Extract air
Class acc. to ISO 16890	ePM ₁ 55 %	ePM ₁₀ 65 %
Class acc. to EN 779	F7	M5
Factory setting of differential pressure switches	250 Pa	350 Pa

Table B10: Air filtration

3.6 Heat recovery system (HRS)

Unit type		RP-6	RP-9
Temperature efficiency, dry	%	77	78
Temperature efficiency, wet	%	89	90

Table B11: Thermal transfer level of the plate heat exchanger

3.7 Technical data of the Belaria® VRF heat pump

Heat pump Belaria®		VRF (33)	VRF (40)	VRF (67)	
Heating	Rated heat output ¹⁾	kW	33.5	40.0	67.0
	Power consumption	kW	7.60	8.51	15.33
	COP	–	4.40	4.70	4.37
	$\eta_{s,h}$	–	173	169	151
	SCOP	–	4.41	4.31	3.86
Cooling	Rated cooling capacity ²⁾	kW	33.5	40.0	67.0
	Power consumption	kW	8.90	9.88	18.10
	EER	–	3.75	4.05	3.70
	$\eta_{s,c}$	–	285	246	277
	SEER	–	7.20	6.22	7.00
Refrigerant	–	R410A	R410A	R410A	
Refrigerant fill volume	kg	11	13	22	

1) With fresh air temperature 7 °C / extract air temperature 20 °C
2) With fresh air temperature 35 °C / extract air temperature 27 °C / 45% rel. humidity

Table B12: Technical data Belaria® VRF

3.8 Heat output

t_F °C	Type RP-	Q kW	Q_{TG} kW	H_{max} m	t_S °C	P_{HP} kW
-5	6-J	33.7	26.8	13.8	32.5	9.3
	6-L	40.3	33.3	12.5	36.0	10.4
	9-N	67.4	58.0	11.9	39.5	18.8
-15	6-J	28.9	18.3	16.5	27.9	9.1
	6-L	34.5	23.9	14.6	30.9	10.2
	9-N	57.7	43.3	13.6	34.1	18.3

Legend:
 t_F = Fresh air temperature
Q = Heat output
 Q_{TG} = Output to cover fabric heat losses
 H_{max} = Maximum mounting height
 t_S = Supply air temperature
 P_{HP} = Power consumption of the heat pump

Reference: Room air 18 °C, extract air 20 °C / 20 % rel. humidity

Table B13: RoofVent® RP heat output

**Notice**

The output for coverage of the fabric heat losses (Q_{TG}) allows for the ventilation heat requirement (Q_V) and the energy recovery output (Q_{ER}) under the respective air conditions. The following applies:

$$Q + Q_{ER} = Q_V + Q_{TG}$$

3.9 Cooling capacity

t _F °C	RH _F %	Type RP-	Q _{sen} kW	Q _{tot} kW	Q _{TG} kW	t _s °C	m _C kg/h	P _{HP} kW
28	40	6-J	22.4	30.7	17.0	12.8	12.2	6.2
		6-L	24.5	33.6	19.1	11.7	13.3	6.4
		9-N	38.2	54.2	30.5	10.7	23.4	11.3
	60	6-J	17.5	35.2	12.1	15.5	25.9	7.5
		6-L	20.9	41.9	15.5	13.7	30.9	8.5
		9-N	32.7	68.3	24.9	12.7	52.4	15.1
32	40	6-J	21.9	34.3	16.5	17.1	18.3	8.1
		6-L	26.1	40.9	20.7	14.8	21.8	9.2
		9-N	42.8	68.6	35.0	13.0	37.9	16.9
	60	6-J	15.1	35.2	9.7	20.8	29.6	8.2
		6-L	18.0	42.0	12.6	19.2	35.3	9.3
		9-N	29.5	70.5	21.8	17.9	60.2	17.0

Legend:
t_F = Fresh air temperature
RH_F = Relative humidity of the fresh air
Q_{sen} = Sensible cooling capacity
Q_{tot} = Total cooling capacity
Q_{TG} = Output for coverage of transmission sensible gains (→ sensible cooling load)
t_s = Supply air temperature
m_C = Condensate quantity
P_{HP} = Power consumption of the heat pump

Reference: ■ At fresh air temperature 28 °C: room air 22 °C, extract air 24 °C / 50 % rel. humidity
■ At fresh air temperature 32 °C: room air 26 °C, extract air 28 °C / 50 % rel. humidity

Table B14: RoofVent® RP cooling capacity



Notice

The output for coverage of transmission sensible gains (Q_{TG}) allows for the ventilation cooling requirement (Q_V) and the output of the energy recovery (Q_{ER}) under the respective air conditions. The following applies:

$$Q_{sen} + Q_{ER} = Q_V + Q_{TG}$$

3.10 Sound level

Position			1	2	3	4	
RP-6	Sound pressure level (at a distance of 5 m) ¹⁾	dB(A)	44	44	52	56	
	Total sound power level	dB(A)	66	66	74	78	
	Octave sound power level	63 Hz	dB	44	43	45	46
		125 Hz	dB	54	54	59	61
		250 Hz	dB	60	60	65	67
		500 Hz	dB	62	62	68	71
		1000 Hz	dB	57	57	71	74
		2000 Hz	dB	55	55	66	70
		4000 Hz	dB	51	51	61	66
8000 Hz	dB	50	49	58	64		
RP-9	Sound pressure level (at a distance of 5 m) ¹⁾	dB(A)	43	42	52	55	
	Total sound power level	dB(A)	65	64	74	77	
	Octave sound power level	63 Hz	dB	44	42	45	45
		125 Hz	dB	55	54	61	62
		250 Hz	dB	58	57	64	65
		500 Hz	dB	61	59	68	70
		1000 Hz	dB	58	56	70	73
		2000 Hz	dB	56	55	67	70
		4000 Hz	dB	50	48	59	64
8000 Hz	dB	44	42	54	59		

1) With hemispherical radiation in a low-reflection environment

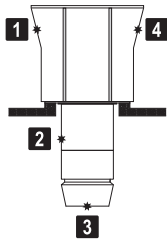

- 1 Fresh air
- 2 Extract air
- 3 Supply air
- 4 Exhaust air

Table B15: RoofVent® RP sound level

Heat pump Belaria®		VRF (33)	VRF (40)	VRF (67)	
Sound pressure level (at a distance of 5 m)	dB(A)	59.0	63.0	67.0	
Total sound power level ¹⁾	dB(A)	81.0	85.0	89.0	
Octave sound pressure level ²⁾	63 Hz	dB	62.6	63.5	66.5
	125 Hz	dB	60.6	61.2	65.0
	250 Hz	dB	61.0	60.8	65.0
	500 Hz	dB	58.3	57.5	63.0
	1000 Hz	dB	55.5	56.9	57.0
	2000 Hz	dB	46.8	47.5	52.0
	4000 Hz	dB	43.9	45.1	51.0
8000 Hz	dB	43.5	44.1	50.2	

1) The values given are maximum values; the noise level is fluctuating due to scroll technology.

2) Measured at a distance of 1 m in front of the unit and 1.3 m above the floor in a semi-anechoic chamber.

Table B16: Sound level Belaria® VRF

3.11 Product information according to ErP

Trademark / Model		Hoval RoofVent® RP			Unit
		6-J	6-L	9-N	
Type		NRVU, BVU			–
Drive		Variable speed drive			–
Heat recovery system		other			–
Thermal efficiency of heat recovery (η_{t_nrvu})		77	77	78	%
Nominal flow rate (q_{nom})		1.53	1.53	2.22	m³/s
Effective electric power input (P)		2.34	2.34	3.69	kW
Internal specific fan power (SFP _{int})		920	920	940	W/(m³/s)
Face velocity		2.69	2.69	2.98	m/s
Nominal external pressure ($\Delta p_{s, ext}$)	Supply air	140	140	290	Pa
	Extract air	190	190	300	
Internal pressure drop of ventilation components ($\Delta p_{s, int}$)	Fresh air/supply air	270	270	268	Pa
	Extract air/exhaust air	300	300	316	
Static efficiency of the fans (η_{fan}) in accordance with Regulation (EU) No. 327/2011		62	62	63	%
Maximum leakage rate	External	0.45	0.45	0.25	%
	Internal	1.5	1.5	1.2	
Energy classification of the filters (class acc. to ISO 16890, final pressure difference)	Supply air ePM ₁ 55 %	250	250	250	Pa
	Extract air ePM ₁₀ 65 %	350	350	350	
Visual filter warning		Displayed on the operating unit			–
Casing sound power level (L _{WA})		73	73	73	dB
Disassembly instructions		Devices that are no longer functional must be dismantled by a specialist company and disposed of at suitable collection points.			–
Contact details		Hoval Aktiengesellschaft Austrasse 70, 9490 Vaduz, Liechtenstein www.hoval.com			

Table B17: Product information according to Commission Regulation (EU) 1253/2014, Article 4(2)

3.12 Dimensions and weights

RoofVent® RP-6

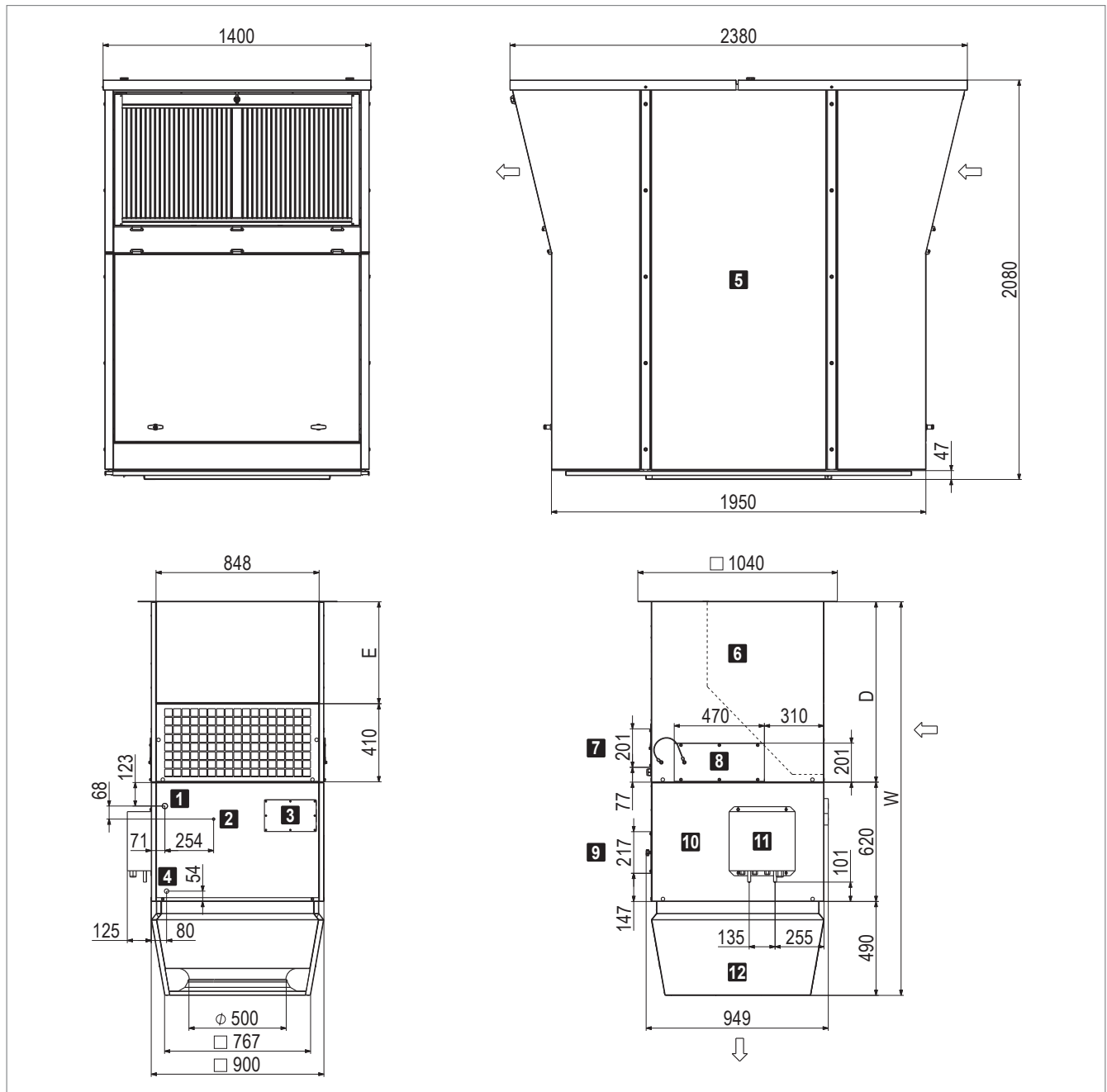

- | | |
|--|--|
| <ul style="list-style-type: none"> 1 Gas line connection (∅ 28 mm) 2 Liquid line connection (∅ 12 mm) 3 Access panel, liquid temperature sensor 4 Condensate connection (G1" external) 5 Roof unit with energy recovery 6 Connection module 7 Access panel, connection box | <ul style="list-style-type: none"> 8 Access panel, coil 9 Access panel, condensate separator 10 Heating/cooling section 11 Combi box RP-6-J: VRF 02 (connection ∅ 12.7 mm) RP-6-L: VRF 03 (connection ∅ 15.9 mm) 12 Air-Injector |
|--|--|

Fig. B4: Dimensional drawing RoofVent® RP-6

Connection module		V0	V1	V2	V3
D	mm	940	1190	1440	1940
E	mm	530	780	1030	1530
W	mm	2050	2300	2550	3050

Table B18: Dimensions RoofVent® RP-6

Unit type		RP-6
Total	kg	911
Roof unit	kg	702
Below-roof unit	kg	209
Air-Injector	kg	37
Heating/cooling section	kg	90
Expansion valve	kg	7
Connection module V0	kg	75
Additional weight V1	kg	+ 11
Additional weight V2	kg	+ 22
Additional weight V3	kg	+ 44

Table B19: Weights RoofVent® RP-6

RoofVent® RP-9

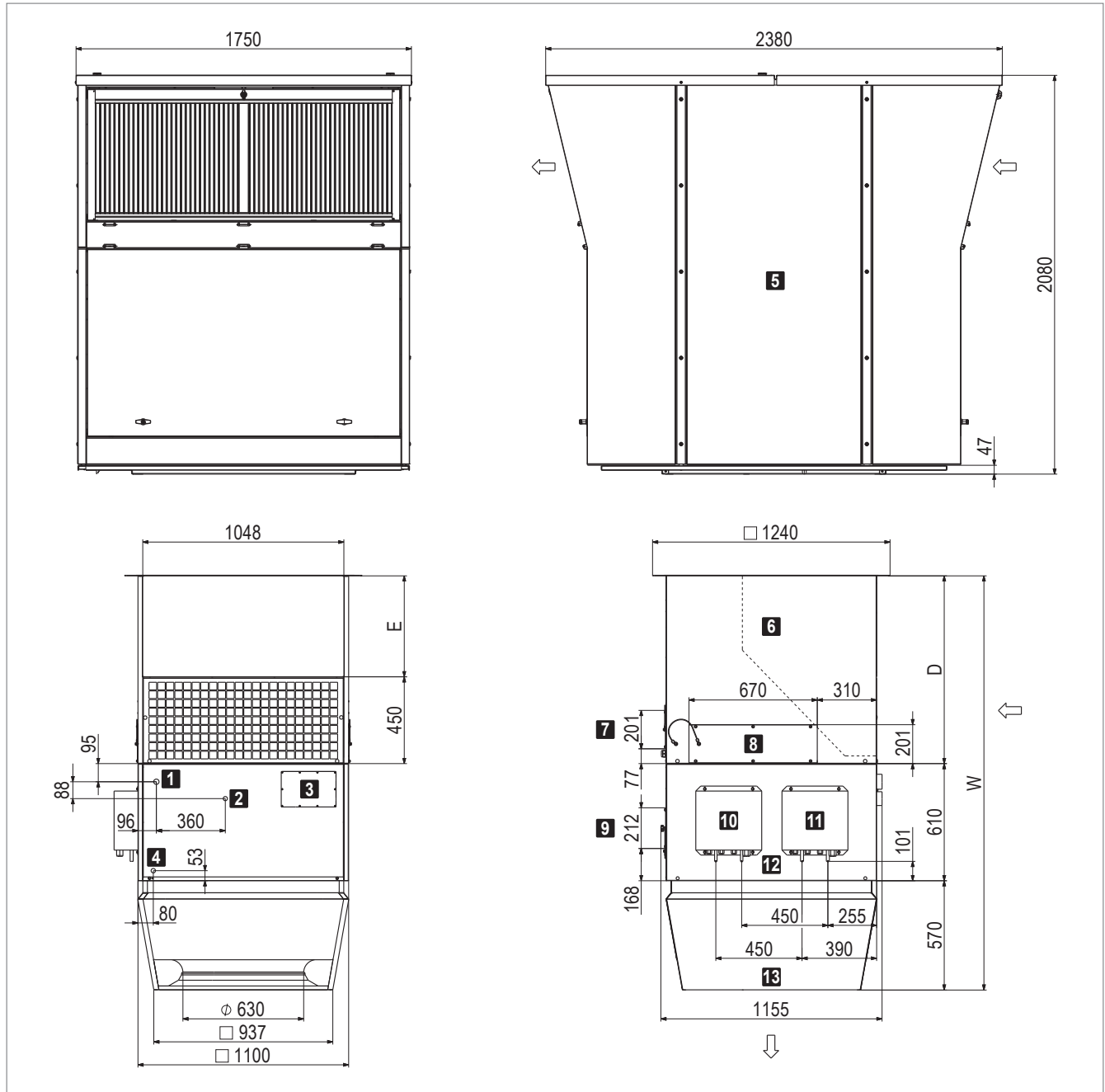

- | | |
|--|---|
| <ul style="list-style-type: none"> 1 Gas line connection (∅ 28 mm) 2 Liquid line connection (∅ 22 mm) 3 Access panel, liquid temperature sensor 4 Condensate connection (G1" external) 5 Roof unit with energy recovery 6 Connection module 7 Access panel, connection box | <ul style="list-style-type: none"> 8 Access panel, coil 9 Access panel, condensate separator 10 Combi box VRF 02 (connection ∅ 12.7 mm) – client 11 Combi box VRF 03 (connection ∅ 15.9 mm) – server 12 Heating/cooling section 13 Air-Injector |
|--|---|

Fig. B5: Dimensional drawing RoofVent® RP-9

Connection module		V0	V1	V2	V3
D	mm	980	1230	1480	1980
E	mm	530	780	1030	1530
W	mm	2160	2410	2660	3160

Table B20: Dimensions RoofVent® RP-9

Unit type		RP-9
Total	kg	1200
Roof unit	kg	904
Below-roof unit	kg	296
Air-Injector	kg	56
Heating/cooling section	kg	132
Expansion valve	kg	14
Connection module V0	kg	94
Additional weight V1	kg	+ 13
Additional weight V2	kg	+ 26
Additional weight V3	kg	+ 52

Table B21: Weights RoofVent® RP-9

Belaria® VRF (33, 40)

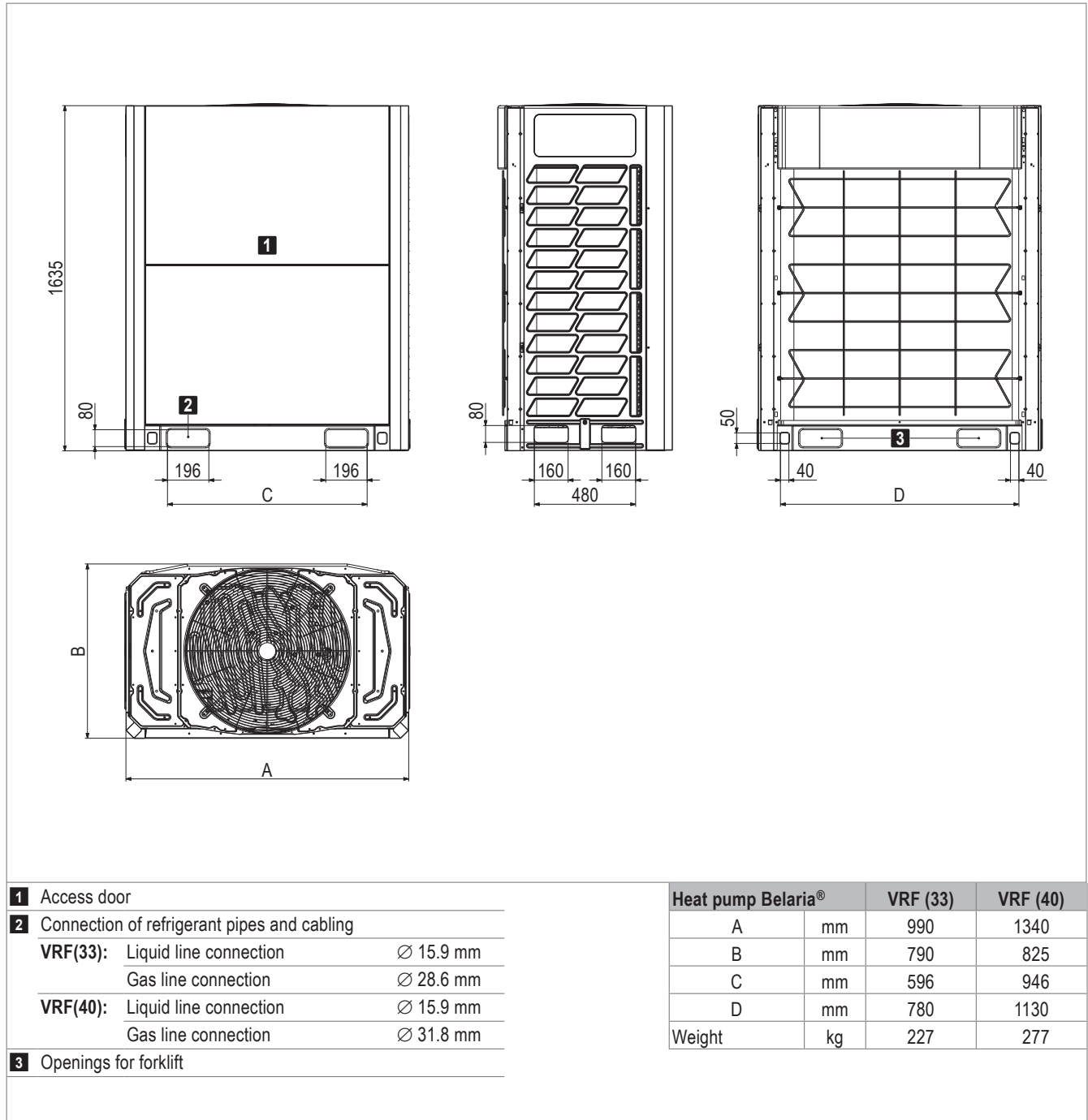

Fig. B6: Dimensions and weights Belaria® VRF (33, 40)

Belaria® VRF (67)

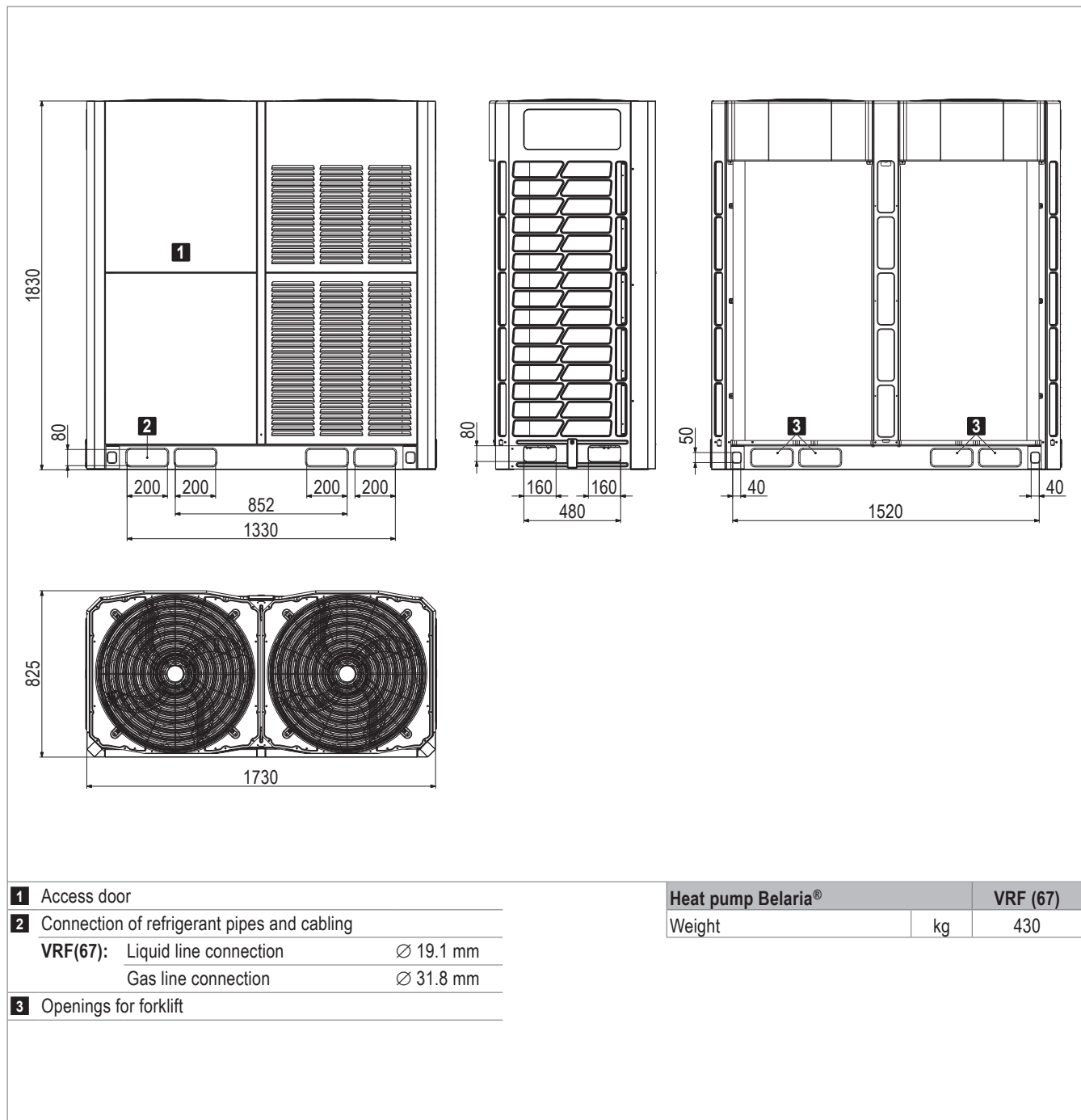

Fig. B7: Dimensions and weights Belaria® VRF (67)

4 Specification texts

4.1 RoofVent® RP

Supply and extract air handling unit with reversible heat pump system for ventilation, heating and cooling spaces up to 25 m in height, equipped with highly efficient air distributor; maximum floor area covered per unit 480 m² (size 6) and 797 m² respectively (size 9).

The unit consists of the following components:

- Roof unit with energy recovery
- Below-roof unit:
 - Connection module
 - Heating/cooling section
 - Air-Injector
- Control components
- Optional components

The heat pump system consists of the following components:

- Heat pump Belaria® VRF (33, 40, 67)
- Conversion board
- Expansion valve

The RoofVent® RP unit complies with all the requirements of the Ecodesign Directive 2009/125/EC relating to environmentally friendly design of ventilation systems. It is a system of the 'non-residential ventilation unit' (NRVU) and 'bidirectional ventilation unit' (BVU) type, provided for in Commission Regulation (EU) 1253/2014.

Roof unit with energy recovery

Self-supporting housing, made of aluminium (outside) and magnesium-zinc sheet and aluminium (inside):

- Weatherproof, corrosion resistant, impact resistant, air-tight
- Low flammability, double-shelled, without heat bridges, with highly efficient insulation made of expanded polystyrene
- Hygienic and easy to maintain because of smooth interior surfaces and large access doors with ageing-resistant, silicone-free sealing materials

The roof unit with energy recovery includes:

Supply air and exhaust air fans

Designed as maintenance-free, direct-drive radial fans with high-efficiency EC motors, backwards-curved, 3D contoured blades and a free-running rotating wheel made of a high-performance composite material; inflow nozzle with optimised flow; infinitely variable speed; with active pressure registration for constant volumetric flow control and/or demand-controlled volumetric flow adjustment; low-noise; with integrated overload protection.

Fresh air filter

Designed as highly efficient compact filter elements, ISO ePM₁ 55 % (F7), fully incinerable, easy to change, including differential pressure switch for filter monitoring.

Extract air filter

Designed as highly efficient compact filter elements, ISO ePM₁₀ 65 % (M5), fully incinerable, easy to change, including differential pressure switch for filter monitoring.

Plate heat exchanger

Crossflow plate heat exchanger made of high-quality aluminium as a highly efficient, recuperative heat recovery system, certified by Eurovent, zero-maintenance, without moving parts, failsafe, hygienically harmless, no cross-contamination of impurities and odours. Equipped with bypass, recirculation bypass, condensate drain and condensation trap to the roof. The following dampers are arranged on the exchanger package:

- Fresh air and bypass dampers, each with their own actuator, for infinitely variable control of the heat recovery; with shut-off function by spring return.
- Extract air and recirculation dampers, interlinked in a counter-rotating arrangement with a common actuator, for controlling the recirculation and mixed air operation; with shut-off function by spring return.

All dampers correspond to seal integrity class 2 according to EN 1751.

Access openings

- Fresh air access door: large access opening with integrated weather and bird protection, configured with quick locking system for easy access to the fresh air filter, the plate heat exchanger as well as the fresh air and bypass dampers.
- Exhaust air access door: large, lockable access opening with integrated weather and bird protection for easy access to the exhaust air fans.
- Extract air access door: large access opening, configured with quick locking system and telescopic support for easy access to the extract air filter, the plate heat exchanger, the condensation trap as well as the extract air and recirculation dampers.
- Supply air access door: large, lockable access opening, configured with telescopic support for easy access to the supply air fans, the control block, the conversion board and the condensate collecting channel.

Control block

Compact design on an easily accessible mounting plate, comprising:

- Unit controller as part of the TopTronic® C control system:
 - Fully wired to the electrical components of the roof unit (fans, actuators, temperature sensors, filter monitoring, differential pressure sensor, conversion board)
 - Pluggable wiring to the control box in the connection module
- High-voltage section:
 - Mains power terminals
 - Isolation switch
 - Button for stopping the fans during filter change
- Low-voltage section:
 - Transformer for actuators, sensors and the unit controller
- Circuit board with further electronic components for unit control (differential pressure measurement, control of heat pump system, fuses for low voltage, ...)

Connection module

Housing made of magnesium-zinc sheet, air-tight, flame retardant, hygienic and easy to maintain because of smooth interior surfaces and ageing-resistant, silicone-free sealing materials; configured with extract air grille and access panel for easy access to the coil for maintenance. The connection module contains:

- Laced wiring harness protected in a sheet metal duct, with direct plug connection to the control block in the roof unit
- Connection box made of magnesium zinc sheet, configured with screw-on cover and cable lead-ins with splash water protection and strain relief; for connection of:
 - Power supply
 - Zone bus
 - Heat pump system
 - All sensors and actuators of the below-roof unit (ready-to-connect)
 - Optional components as required

Connection module V1 / V2 / V3:

The connection module is extended for adapting to the local installation situation.

Heating/cooling section

Housing made of magnesium zinc sheet, air-tight, flame retardant, hygienic and easy to maintain because of smooth internal surfaces and ageing-resistant, silicone-free sealing materials, internally insulated with close-pored polyurethane. The heating/cooling section contains

- The highly efficient heating/cooling coil consisting of seamless copper pipes with pressed-on, optimised and profiled aluminium fins, manifold made of copper and injection distributor
- The pull-out condensate separator with collecting channel, made of high-quality corrosion-resistant material, with a downslope in all directions for rapid draining
- The condensate trap for connecting to a condensate drain (supplied)

Air-Injector

1 Air-Injectors

Casing made of magnesium zinc sheet, air-tight, flame retardant, hygienic and easy to maintain because of ageing-resistant, silicone-free sealing materials, internally insulated with closed-cell polyethylene foam, with:

- Vortex air distributor with concentric outlet nozzle, adjustable vanes and integrated absorber hood
- Actuator for infinitely variable adjustment of the air distribution from vertical to horizontal
 - for draught-free air distribution in the hall under changing operating conditions
 - for the rapid and large-area reduction of temperature stratification in the room through induction of secondary air and strong mixing of the room air with supply air
- Supply air temperature sensor

2 Air-Injectors

2x Air-Injectors, supplied loose; supply air duct for connecting the RoofVent® unit to the Air-Injectors on site.

Casing made of magnesium zinc sheet, air-tight, flame retardant, hygienic and easy to maintain because of ageing-resistant, silicone-free sealing materials, internally insulated with closed-cell polyethylene foam, with:

- Vortex air distributor with concentric outlet nozzle, adjustable vanes and integrated absorber hood
- Actuator for infinitely variable adjustment of the air distribution from vertical to horizontal
 - for draught-free air distribution in the hall under changing operating conditions
 - for the rapid and large-area reduction of temperature stratification in the room through induction of secondary air and strong mixing of the room air with supply air
- Supply air sensor (supplied in the connection module)

Without Air-Injector

Unit configured without vortex air distributor for connection to an on-site supply air duct and air distribution within

the building, supply air temperature sensor supplied in the connection module.

Options for the unit

Paint finish of below-roof unit

Choice of external paint finish in RAL colour.

Fresh air and exhaust air silencers

Fresh air silencer configured as add-on part for the roof unit which can be folded downwards, housing made of aluminium with a bird screen and acoustic insulation lining, for reducing sound emissions on the fresh air side; exhaust air silencer configured as add-on part for the roof unit which can be folded downwards, housing made of aluminium with bird screen and easily accessible sound attenuation splitters, optimised flow, with abrasion-resistant and easily cleaned surfaces, non-flammable, hygienically clean with high-quality glass filament cover for reducing sound emissions on the exhaust air side, insertion loss fresh air/exhaust air _____ dB / _____ dB

Supply air and extract air silencers

Supply air silencer configured as separated component in the below-roof unit, flow-optimised sound attenuation splitters, with abrasion-resistant and easily cleaned surfaces, non-flammable, hygienically clean with high-quality glass filament cover, extract air silencer configured as acoustic insulation lining in the connection module, for reducing sound emission in the room, insertion loss supply air/extract air _____ dB / _____ dB

Condensate pump

Consisting of a centrifugal pump and a drip tray, max. delivery rate of 150 l/h with a delivery head of 3 m.

Socket

230 V socket installed in the control block for simple supply of external, electrical units.

Energy monitoring

Consisting of 2 additional temperature sensors for recording the air inlet and air outlet temperatures of the plate heat exchanger. Energy monitoring makes it possible to display the energy saved by heat and cool recovery.

Heat pump system

Highly efficient air-to-air heat pump system in split design with continuously modulating inverter technology for precise capacity control, reversible for heating and cooling the supply air, consisting of the following components:

Heat pump Belaria® VRF (33, 40, 67)

- Compact unit for outdoor installation
- Painted casing RAL 7044 (silk grey) made from galvanised sheet steel
- Variable-speed inverter scroll compressor
 - 1 × for Belaria® VRF (33, 40)
 - 2 × for Belaria® VRF (67)
- Speed-controlled fan
 - 1 × for Belaria® VRF (33, 40)
 - 2 × for Belaria® VRF (67)
- Coated Al/Cu finned-tube evaporator or condenser
- Electronic expansion valve (for heating mode)
- 4-way valve for defrosting
- Refrigerant shut-off valves
- Refrigerant R410A
- Terminal box

Conversion board

Printed circuit board assembly for communication between heat pump, expansion valve and indoor climate unit and for recording the temperatures of the refrigerant upstream, in and downstream of the heating/cooling coil. Mounted and fully wired in the roof unit of the indoor climate unit.

- 1 × for Belaria® VRF (33, 40)
- 2 × for Belaria® VRF (67)

Expansion valve

Electronic expansion valve for cooling mode, mounted in the combi box, thermally insulated and protected against mechanical damage.

- 1 × for Belaria® VRF (33, 40)
- 2 × for Belaria® VRF (67)

On-site: mounting of the combi box to the below-roof unit

Options for the heat pump

Rear protection hood

Hood made of magnesium zinc sheet, powder-coated (RAL 7044 silk grey), for protection against wind and snow. On-site: Mounting to the heat pump.

Side protection hood

Hood made of magnesium zinc sheet, powder-coated (RAL 7044 silk grey), for protection against wind and snow. On-site: Mounting to the heat pump.

Front protection hood

Hood made of magnesium zinc sheet, powder-coated (RAL 7044 silk grey), for protection against wind and snow. On-site: Mounting to the heat pump.

4.2 TopTronic® C – System control

Zone-based control system for the energy-optimised operation of decentralised Hoval indoor climate systems. Maximum system size per system bus: 64 control zones with up to 10 supply and extract air handling units or supply air handling units and 10 recirculation air handling units each.

Zone allocation

Configured in advance for the customer at the factory:

	Room designation	Unit type
Zone 1:	_____	_____
Zone 2:	_____	_____
...		

System structure

- Zone control panel made of coated sheet steel (light grey RAL 7035), ... x ... x ... mm, with:
 - System operator terminal
 - Fresh air temperature sensor
 - 1 zone controller and 1 room temperature sensor per zone (expandable to up to 4 room temperature sensors per zone)
 - Safety relay
 - Electrical cabinet internally pre-wired, all components routed to terminals
- Zone bus: as serial bus for communication with all controllers in one control zone, with robust bus protocol via shielded, twisted bus cable (provided by the client)
- Unit controller: installed in the particular indoor climate unit, works autonomously according to the specifications of the zone controller
- Heating/cooling demand per zone with feedback monitoring

Functions, standard

- Zone-based autonomous room control. Temperature and ventilation control separately adjustable for each zone
- Room temperature control via room-supply air cascade by means of energy-optimised double sequence control with priority circuit for energy recovery (supply and extract air handling units)
- Intelligent automatic heating to reach the desired room temperature at the switching time
- 5 adjustable room temperature set values per zone:
 - Cooling protection (lower setpoint in standby)
 - Overheating protection (upper setpoint in standby)
 - Room set value winter
 - Room set value summer
 - Night cooling set value (free cooling) (supply and extract air handling units, supply air units)
- Destratification mode for even temperature distribution

- Main operating modes of supply and extract air handling units:

VE Ventilation, infinitely variably adjustment
 AQ.... Air quality, automatic control with Hoval combination sensor (option), optional reference variable:

- CO₂ or VOC
- Air humidity (optimised dehumidification mode)

REC . Recirculation, infinitely variably adjustment

DES.. Destratification

EA Exhaust air, infinitely variably adjustment

SA Supply air, infinitely variably adjustment

ST Standby

- Main operating modes of supply air units:

REC . Recirculation, infinitely variably adjustment

DES.. Destratification

SA Supply air, infinitely variably adjustment

With Hoval combination sensor (option) also demand-driven control of the fresh air ratio, optional reference variable CO₂ or VOC

ST Standby

- Main operating modes of recirculated air units:

REC . Recirculation, infinitely variably adjustment

DES.. Destratification

ST Standby

- Forced heating (construction site heating) can be activated on each device before completion of the overall system (activation by Hoval service technician)
- Control of draught-free air distribution with the Hoval Air-Injector: the discharge direction is adjusted infinitely variably and automatically according to the respective operating condition and the existing temperatures (heating/cooling).

Operation

- TopTronic® C-ST system operator terminal: touch panel for visualisation and control of all Hoval indoor climate units registered on the bus

Options for operation

- Hoval C-SSR operating software, for visualisation on customer's PC
- TopTronic® C-ZT as zone operator terminal: for simple on-site operation of a control zone
- Manual operating selector switches
- Manual operating selector buttons
- Operating of the units via building management system via standardised interfaces:
 - BACnet
 - Modbus IP
 - Modbus RTU

Alarms, protection

- Central alarm management with registration of all alarms (timestamp, priority, status) in an alarm list and alarm memory of the last 50 alarms; forwarding via e-mail can be set in the parameters.
- If there is a failure of communication, bus stations, sensor systems or supply media, each part of the system transitions to a protection mode which safeguards operation.
- A maintenance mode implemented in the control algorithm for testing all physical data points and alarms guarantees high reliability.
- Pre-programmed data points retrievable via logger function for 1 year

Options for the zone control panel

- Alarm lamp
- Socket

Per zone:

- The change-over between heating and cooling can be either automatic or manual
 - Cooling lock switch for automatic changeover
 - Heating/cooling switch for manual changeover
- Additional room temperature sensors (max. 3)
- Combination sensor room air quality, temperature and humidity
- Combination sensor fresh air temperature and humidity
- Transfer of actual values and setpoints from external systems (0...10 V; 4 - 20 mA)
- Load shedding input
- Signal for external extract air fan
- Operating selector switches on terminal
- Operating selector button on terminal
- Control of distributor pump, incl. power supply

Power distribution:

- Circuit breakers and output terminals for Hoval indoor climate units
- Safety relay (4-pin)



Options

1 Type code 34

2 Connection module. 36

3 Design with 2 Air-Injectors 36

4 Design without Air-Injector 36

5 Paint finish of below-roof unit 36

6 Fresh air and exhaust air silencers 37

7 Supply air and extract air silencers 38

8 Condensate pump 38

9 Socket 39

10 Energy monitoring. 39

11 Options for the heat pump 39

1 Type code

RP - 6 - L - RX / ST . -- / V0 . D1 . LU / AF . SI / - . KP . -- . SD / TC . EM . -- . --

Unit type

RoofVent® RP

Unit size

6 or 9

Heating/cooling section

- J with coil type J for Belaria® VRF (33)
- L with coil type L for Belaria® VRF (40)
- N with coil type N for Belaria® VRF (67)

Heat recovery

RX Temperature efficiency ErP 2018

Design

ST Standard

Connection module

- V0 Standard
- V1 Length + 250 mm
- V2 Length + 500 mm
- V3 Length + 1000 mm

Air outlet

- D1 Design with 1 Air-Injector
- D2 Design with 2 Air-Injectors
- D0 Design without Air-Injector

Paint finish

- without
- LU Paint finish of below-roof unit

Silencers outside

- without
- AF Fresh air and exhaust air silencers

Silencers inside

- without
- SI Supply air and extract air silencers

Condensate pump

- without
- KP Condensate pump

RP - 6 - L - RX / ST . -- / V0 . D1 . LU / AF . SI / - . KP . -- . SD / TC . EM . -- . --

Socket

- without
- SD Socket in the unit
- CH Socket in the unit Switzerland

Control system

- TC TopTronic® C

Energy monitoring

- without
- EM Energy monitoring

Table C1: Type code



2 Connection module

The connection module is available in 4 lengths for adapting the RoofVent® unit to local conditions.

3 Design with 2 Air-Injectors

To distribute the supply air over a very wide area, a supply air duct provided by the client can be connected to the RoofVent® unit. 2 Air-Injectors can be installed on this.

Please note the following:

- 2 air distributors size 6 are supplied.
- Install the 2 air distributors on the supply air duct.
- Wire up the 2 actuators of the air distributors to the connection box.
- The supply air temperature sensor is enclosed. Install it in the supply air duct and wire it up to the connection box.

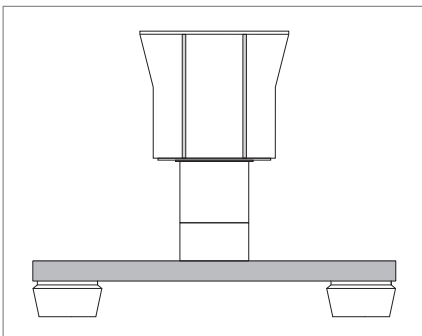

Fig. C1: RoofVent® unit with supply air duct and 2 Air-Injectors

4 Design without Air-Injector

RoofVent® units in the design without Air-Injector are suitable for connecting to an air distribution system supplied by the client. Please note the following:

- The supply air temperature sensor is enclosed. Install it in the supply air duct and wire it up to the connection box.

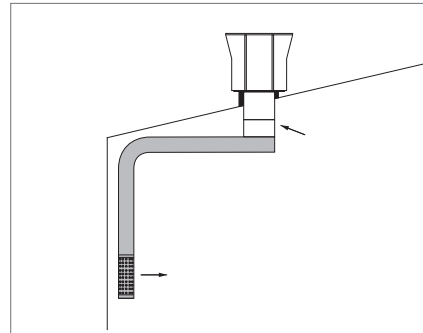

Fig. C2: Connection to an air distribution system supplied by the client (for dimensions see Table C2).

5 Paint finish of below-roof unit

The entire below-roof unit including optional components is painted in any colour.

A technical drawing showing the connection dimensions for the supply air duct. The drawing includes a main view and a detailed view of the connection point. The main view shows dimensions X and V. The detailed view shows dimensions 20, 28, and 25.

Size		6	9
X	mm	850	1050
V	mm	900	1100

Table C2: Connection dimensions supply air duct (in mm)

6 Fresh air and exhaust air silencers

The fresh air silencer reduces noise emissions from RoofVent® units on the fresh air side. It consists of an aluminium casing with a bird screen and acoustic insulation lining and is configured as an add-on part for the roof unit which can be folded downwards.

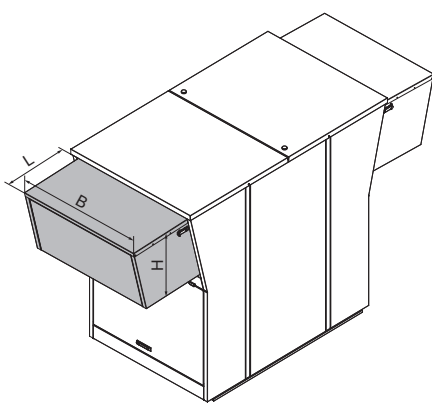

Size		6	9
L	mm	625	625
B	mm	1280	1630
H	mm	650	650
Weight	kg	30	42
Pressure drop	Pa	10	10

Table C3: Technical data fresh air silencer

Frequency	Size 6	Size 9
63 Hz	0	0
125 Hz	1	1
250 Hz	3	3
500 Hz	4	4
1000 Hz	4	4
2000 Hz	4	4
4000 Hz	3	3
8000 Hz	3	3
Total	3	3

Table C4: Insertion attenuation fresh air silencer (values in dB, relating to the nominal air flow rate)

The exhaust air silencer reduces noise emissions from RoofVent® units on the exhaust air side. It consists of an aluminium casing with a bird screen and sound attenuation splitters and is configured as an add-on part for the roof unit which can be folded downwards.

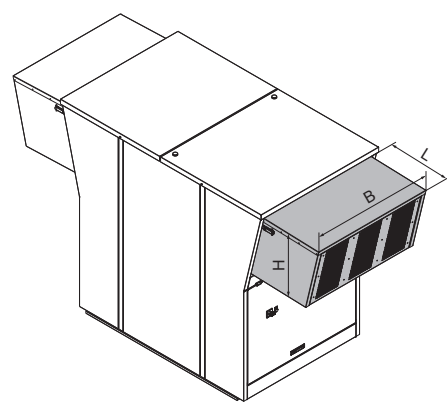

Size		6	9
L	mm	625	625
B	mm	1280	1630
H	mm	650	650
Weight	kg	52	68
Pressure drop	Pa	50	53

Table C5: Technical data exhaust air silencer

Frequency	Size 6	Size 9
63 Hz	2	2
125 Hz	3	3
250 Hz	9	9
500 Hz	11	11
1000 Hz	15	15
2000 Hz	14	14
4000 Hz	10	10
8000 Hz	8	8
Total	11	11

Table C6: Insertion attenuation exhaust air silencer (values in dB, relating to the nominal air flow rate)

7 Supply air and extract air silencers

Supply air and extract air silencers reduce the noise from RoofVent® units within the room. The supply air silencer is designed as a separated component and is installed above the Air-Injector. The extract air silencer consists of acoustic insulation lining in the connection module.

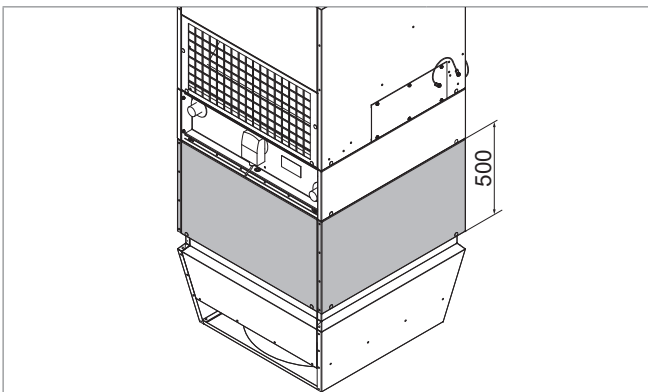

Size		6	9
Weight	kg	53	80
Supply air pressure drop	Pa	22	26
Extract air pressure drop	Pa	0	0

Table C7: Technical data supply air and extract air silencers

Frequency	Supply air		Extract air	
	Size 6	Size 9	Size 6	Size 9
63 Hz	7	5	0	0
125 Hz	9	7	0	0
250 Hz	15	15	2	2
500 Hz	17	17	3	3
1000 Hz	19	20	3	3
2000 Hz	15	17	3	3
4000 Hz	13	12	2	2
8000 Hz	10	9	2	2
Total	15	15	2	2

Table C8: Insertion attenuation supply and extract air silencers (values in dB, relating to the nominal air flow rate)

8 Condensate pump

RoofVent® cooling units must be connected to a condensate drainage system. For applications in which connection to the waste water system is too expensive or not possible for structural reasons, a condensate pump can be provided. This is installed directly under the condensate drain connection; the supplied container is prepared for installation on the unit. It pumps the condensate through a flexible hose to a delivery head of 3 m, thus enabling discharge of the condensate

- through waste water pipes directly below the ceiling,
- onto the roof.

Flow rate (at 3 m delivery head)	l/h	max. 150
Tank capacity	l	max. 1.9
Dimensions (L x W x H)	mm	288 x 127 x 178
Weight	kg	2.4
Nominal voltage	V AC	230
Power consumption	kW	0.1
Current consumption	A	0.43

Table C9: Condensate pump technical data

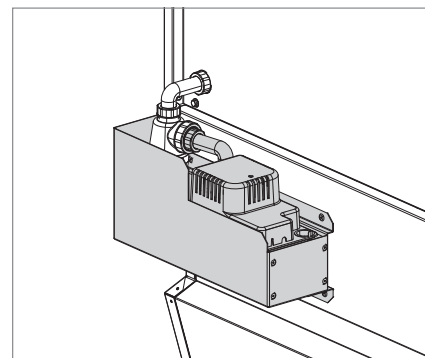

Fig. C3: Condensate pump

9 Socket

For maintenance work, a socket (1-phase, 230 V AC, 50 Hz) can be installed in the roof unit, next to the control block.

10 Energy monitoring

Energy monitoring makes it possible to display the energy saved by heat and cool recovery. For this purpose, 2 additional temperature sensors are installed in the RoofVent® units; they record the air inlet and air outlet temperatures of the plate heat exchanger.

11 Options for the heat pump

11.1 Protection hood

To protect the heat pump from strong winds and snowfall, protection hoods are available as accessories. They are supplied loose with the appropriate connecting screws for assembly on site.

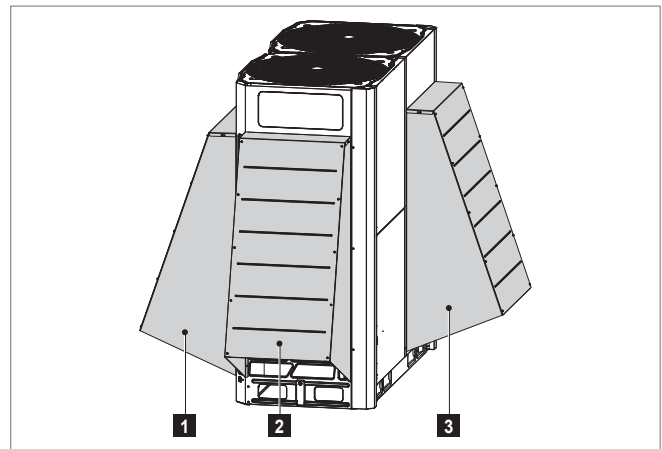

- 1** Rear protection hood
- 2** Side protection hood
- 3** Front protection hood

Fig. C4: Belaria® VRF (67) heat pump with protection hoods

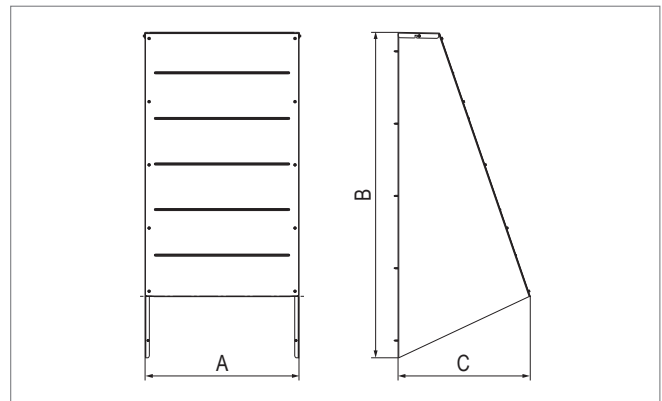

Belaria®	Protection hood	Qty.	A	B	C
VRF (33)	Side PS-33	2	578	1222	497
	Rear PR-33	1	842	1222	497
VRF (40)	Side PS-40	2	578	1222	497
	Rear PR-40	1	1192	1222	497
VRF (67)	Side PS-67	2	600	1396	557
	Rear PR-67	2	760	1378	550
	Front PF-67	1	760	1378	550

Table C10: Quantity and dimensions of protections hoods (in mm)

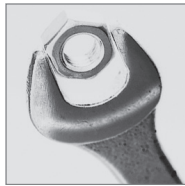

Transport and installation

1 Installation	42
2 Refrigeration system installation	48
3 Hydraulic installation	50
4 Electrical installation	50

1 Installation

1.1 Preparation

The scope of delivery includes:

- RoofVent® unit, delivered in 2 parts on pallets (roof unit, below-roof unit)
- Heat pump Belaria® VRF
- Accessories (installation material, extract air filter, trap, temperature sensors, combi box)
- Optional components

The units are installed in or on the roof. A crane or helicopter is required.

RoofVent® unit

- The units are delivered screwed onto the pallet. To loosen the screws, the inspection doors must be opened. When unloading the units, make sure that there is enough space to open the inspection doors.
- Transport eyes are supplied for lifting the below-roof unit and the roof unit.
 - A ladder will be required to screw in the transport eyes.
 - Use lifting ropes at least 2 m in length to lift the below-roof unit.
 - Use lifting ropes at least 3 m in length to lift the roof unit.
- Depending on the unit size, the below-roof unit can be delivered in 2 parts.
- Make sure that the roof frame corresponds to the specifications in chapter 1.3.
- A sealing compound is required for sealing (e.g. Sikaflex® 221).
- Define the desired orientation of the units (position of the refrigerant connections).



Notice

The standard position of the refrigerant connections is underneath the extract air grille. Check the local installation conditions. If another orientation is required, the heating/cooling section can be mounted turned round on the connection module.

- Fresh air and exhaust air silencers are supplied separately. Install them on the unit before transporting it to the roof, and make sure they are locked.
- Follow the installation instructions included.



Notice

Provide suitable protective devices and make sure the units can be accessed easily. The maximum roof load of the RoofVent® units is 80 kg.

Heat pump Belaria® VRF

- Lifting the heat pump with a crane:
 - Use 2 straps at least 8 m in length.
- Lifting the heat pump with a forklift:
 - Transport to the installation site: Lift the unit under the pallet.
 - Unloading from the pallet: Guide the forklift tines into the large rectangular openings under the device.

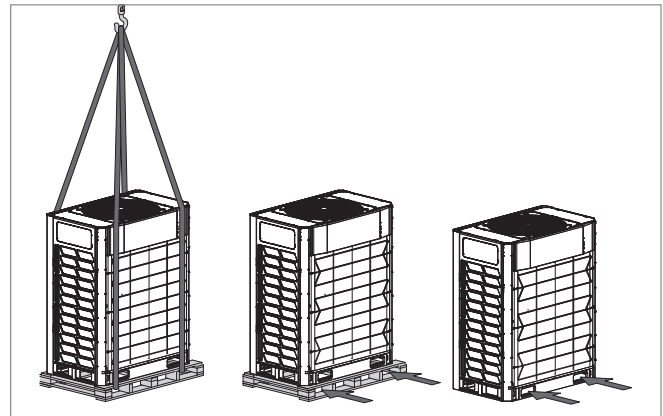
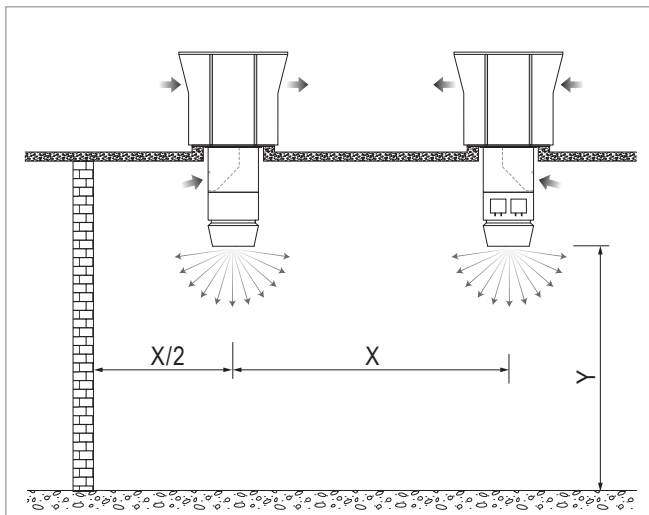

Fig. D1: Lifting the heat pump

1.2 Positioning

RoofVent® unit

- Comply with the minimum and maximum distances.
- Pay attention to the alignment of the units relative to each other. Units must not draw in exhaust air from other units as fresh air.
- All air inlet and air outlet openings must be freely accessible. The supply air jet must be free to spread out unhindered.
- The access doors in the roof unit and the access panels in the below-roof unit must be easily accessible.
- Clearance of at least 0.9 m is required for maintenance work around the heating/cooling section and, if applicable, the supplementary heater.



Size		6	9
Distance X	min.	m 11	13
	max.	m 22	28
Mounting height Y	min.	m 4	5
	max. ¹⁾	m	Approx. 9...25

1) The maximum mounting height varies depending on the boundary conditions (for values, see table of heat outputs or calculation with the 'HK-Select' selection program)

Table D1: Minimum and maximum distances

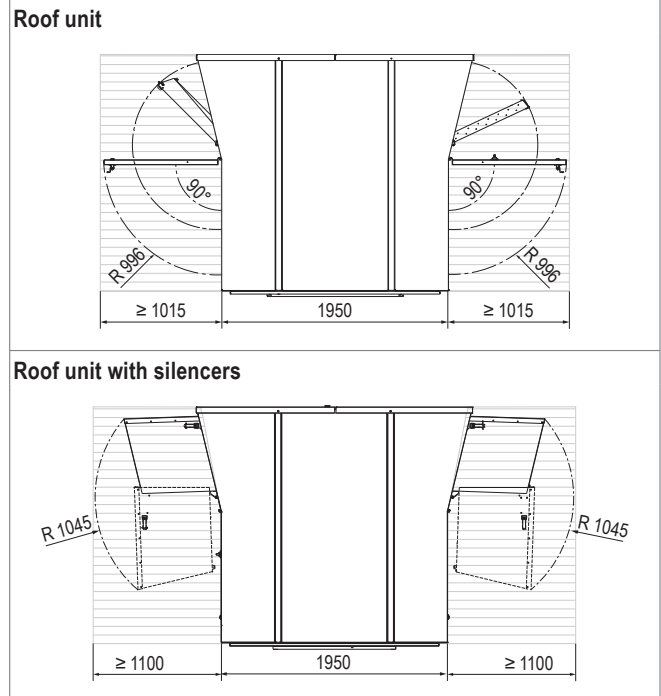

Fig. D2: Space requirements for maintenance on the roof (dimensions in mm)



Notice

If side access is not possible, proportionally more space is required for opening the access doors.

Heat pump Belaria® VRF

- Place the heat pump as close as possible to the indoor climate unit, in a well ventilated location.



Notice

Excessively long refrigerant lines reduce the efficiency of the system. Place the heat pump as close as possible to the indoor climate unit.

- Note the following when choosing a location:
 - Not near a heat source with high temperature
 - Not in locations where dust or dirt can affect the heat exchangers
 - Not in locations with mineral oil vapours in the air
 - Not in locations with acidic or alkaline vapours in the air
 - Not in locations with a high salt content in the air
- Observe the minimum distances for sufficient air flow through the heat pump.
- Place the heat pump on a solid base with sufficient load-bearing capacity to avoid vibrations and noise.
- Install the heat pump on a solid base made of concrete or steel:
 - The base must be at least 200 mm high to allow sufficient space for the installation of the pipelines.
 - The base must be flat and level. The support points must bear the weight evenly.
 - Water must be free to drain through the base plate of the heat pump.
- In areas with heavy snowfall:
 - Increase the base height to ensure that the unit operation is not affected by snow.
 - Protect the heat pump with protection hoods (option).

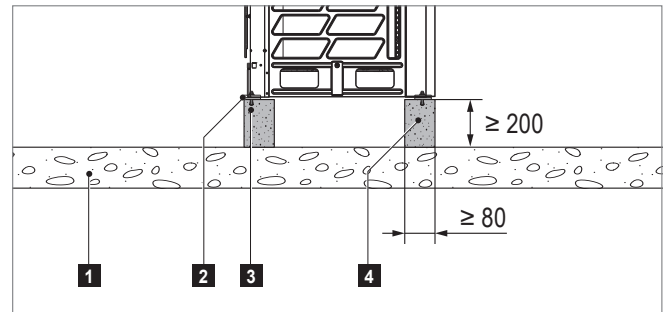

- Firm ground
- Vibration damper
- Expansion anchor \varnothing 10 mm
- Base made of concrete or steel

Fig. D4: Base for the heat pump

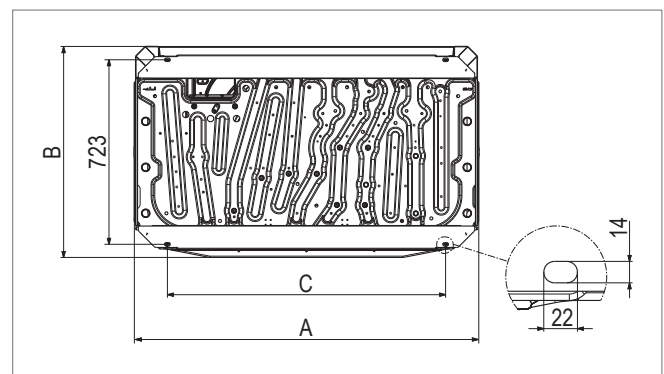

Dimension	VRF (33)	VRF (40)	VRF (67)
A	990	1340	1730
B	790	825	825
C	740	1090	1480

Table D2: Position of the screw connections (dimensions in mm)

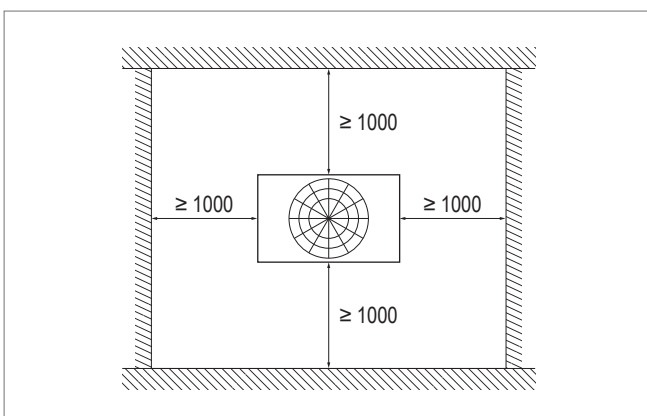

Fig. D3: Minimum distances for the heat pump (dimensions in mm)

1.3 Roof frame

Roof frames are required for installing RoofVent® units in the roof. Please consider the following in the design process:

- The extract air grille and the access panels must be freely accessible under the roof.
- The roof frame must protrude at least 200 mm from the roof, so that no water can penetrate during a rainstorm or snowfall.



Notice

The connection module is available in 4 lengths for adapting to the local installation situation.

- The opening (dimension Z2) must be large enough to accommodate the below-roof unit.
- The condensate must be able to drain off freely.
- The roof frame must be flat and horizontal.
- Insulate the roof frame before installing the unit (thermal insulation).
- Please observe the minimum distances when designing the roof frame (see chapter 1.2). Change the orientation of the refrigerant connections, if necessary.

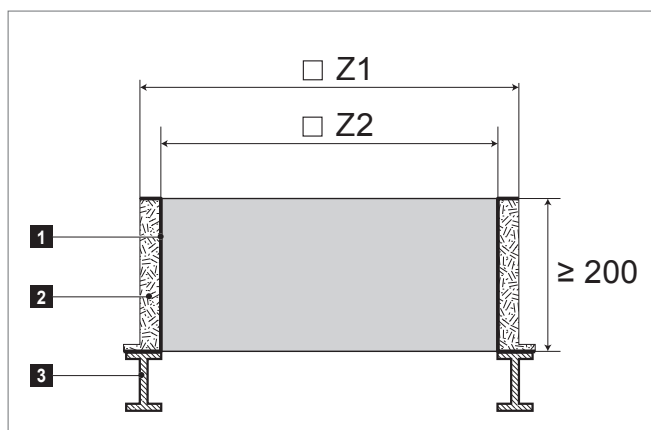

- 1 Weight-bearing inner wall of the roof frame
- 2 Insulation
- 3 IPE beam

Size			6	9
Z1	max.	mm	1110	1460
	min.	mm	962	1162
Z2	min.	mm	970	1170
	max.	mm		

Table D3: Dimensions for roof frame

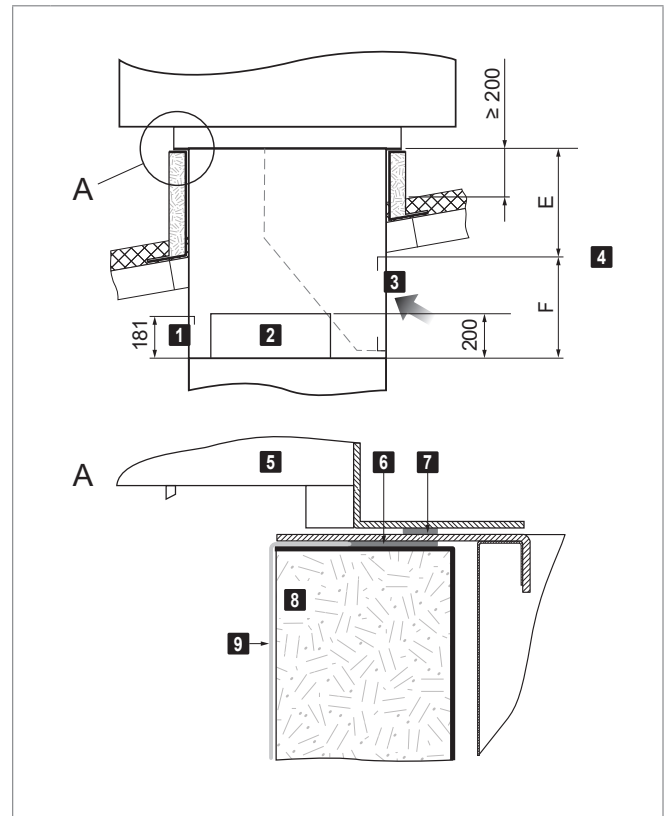

- 1 Access panel, connection box
- 2 Coil access panel (both sides)
- 3 Extract air grille
- 4 Dimensions E and F see 'Technical data' chapter
- 5 Roof unit
- 6 Sealing compound (on site)
- 7 Sealing strip (fitted at the factory)
- 8 Roof frame
- 9 Membrane

Fig. D5: Installation of RoofVent® units in the roof frame (dimensions in mm)

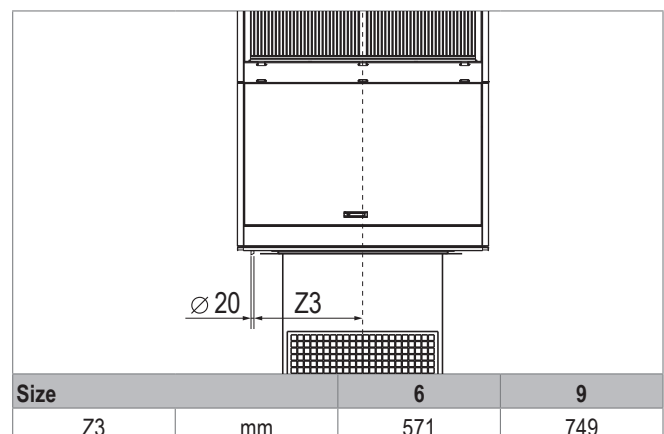

Table D4: Condensate drain of the plate heat exchanger (measured from unit centre)

Size			6	9
Z3	mm		571	749

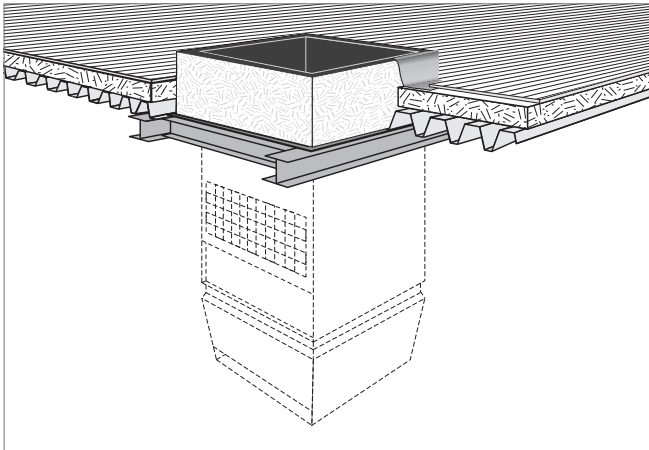

Fig. D6: Conceptual drawing of the roof frame

Depending on local conditions, 2 different types of roof frame can be used:

- Roof frame with straight side walls (where there is sufficient space)
- Roof frame with conical side walls (where a below-roof unit protruding into the room interferes with the crane-ways, for example)



Notice

Ensure there is sufficient clearance for maintenance work (see chapter 1.2).

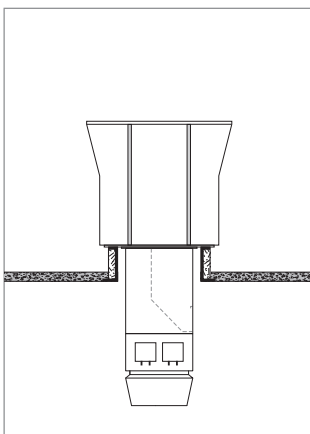

Fig. D7: Roof frame with straight side walls

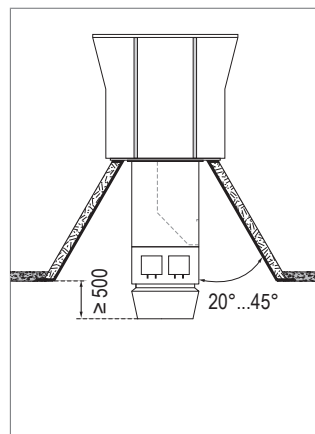

Fig. D8: Roof frame with conical side walls

1.4 Unit installation

Proceed as follows to position the unit:

Below-roof unit

- Apply sealing compound to the roof frame.
- Screw in the transport eyes and attach the lifting gear.
- Transport the below-roof unit to the roof frame using a helicopter or crane.
- Turn the below-roof unit to the desired position.
- Hang the below-roof unit into the roof frame from above.

Roof unit

- Remove the cover caps on the unit roof.
- Screw in the transport eyes and attach the lifting gear.
- Transport the roof unit to the roof, correctly position the roof unit over the below-roof unit and set it down.
- Screw the roof unit to the below-roof unit.
- Remove the transport eyes and refit the cover caps.

Heat pump Belaria® VRF

- Transport the heat pump to the installation site.
- Place the unit on the prepared frame.
- Fasten the unit with 4 expansion anchors \varnothing 10 mm.
- Fit the combi box on the heating cooling section of the below-roof unit.

1.5 Duct connection

If necessary, it is possible to connect an extract air duct to the below-roof unit instead of the extract air grille.

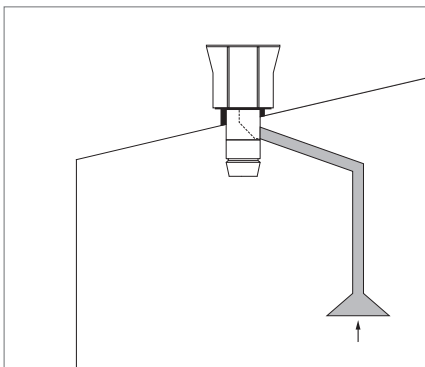
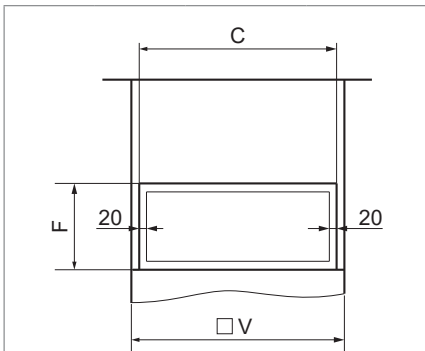

Fig. D9: Extract air duct



Size		6	9
C	mm	848	1048
F	mm	410	450
V	mm	900	1100

Table D5: Connection dimensions (in mm)

2 Refrigeration system installation

The refrigerant pipes must be installed by a qualified refrigeration technician in line with the local regulations.

To avoid damaging the unit:

- Do not use any flux.
- Ensure there is a nitrogen supply when soldering.
- Insulate the refrigerant pipes.
- Carry out a leak-tightness test and vacuum drying.

2.1 Refrigerant pipes

- Install the refrigerant pipes as shown in Fig. D12 to Fig. D14 schematically according to the local conditions. The maximum length for the flow and the return is 40 m each.



Notice

Excessively long refrigerant lines reduce the efficiency of the system. Place the heat pump as close as possible to the indoor climate unit.

- The material to be used and the pipe thickness depend on the pipe diameter:

Pipe diameter	Material	Pipe thickness
Ø 12.7 mm	Hardened copper	0.8 mm
Ø 15.9 mm		1.0 mm
Ø 19.1 mm		1.0 mm
Ø 28.6 mm	Semi-hard copper	1.3 mm

Table D6: Configuration of refrigerant pipes

- The thickness of the insulation depends on the pipe diameter. Minimum thicknesses are given in Table D7. Thicker insulation is required in hot, humid environments.

Pipe diameter	Minimum thickness of the insulation ¹⁾	Material
Ø 12.7 mm	15 mm	Closed-cell foam, fire protection class B1, temperature-resistant up to 120 °C, outer insulation UV-resistant
Ø 15.9 mm	20 mm	
Ø 19.1 mm	20 mm	
Ø 28.6 mm	20 mm	

¹⁾ Increase the thickness of the insulation in hot, humid environments (> 80% relative humidity).

Table D7: Insulation of the refrigerant pipes

- 2 expansion valves are required for the Belaria® VRF (67). Use the branching kit supplied for branching the pipeline.
 - Install the branching kit so that the two branch pipes are in one plane.

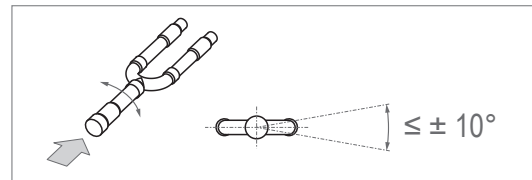

Fig. D10: Installation of the branching kit

- If the heat pump is placed more than 20 m higher than the heating/cooling coil: Install an oil return trap in the gas line every 10 m.

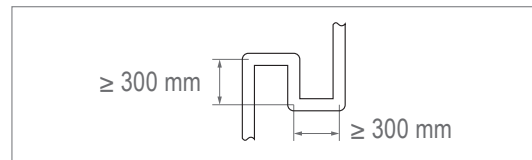

Fig. D11: Oil return trap

2.2 Calculation of the additional refrigerant fill

- The heat pump is filled with refrigerant at the factory:
 - Refrigerant R410A
- Depending on the unit size, the heat pump is only partially pre-filled at the factory, and so refrigerant must be added on site:

Belaria®		VRF (33)	VRF (40)	VRF (67)
Pre-fill volume	kg	11.0	11.8	11.8
Top-up volume	kg	–	1.2	10.2
Total fill volume	kg	11.0	13.0	22.0

Table D8: Refrigerant fill of the heat pump

- In addition, refrigerant must be topped up depending on the length and diameter of the liquid line (from the heat pump to the expansion valve).
 - Ø 12.7 mm . . . 0.11 kg refrigerant per metre length
 - Ø 19.1 mm . . . 0.26 kg refrigerant per metre length
- The entire top-up volume is calculated as follows:

Top-up volume of heat pump	=	_____
+ _____ m (Ø 12.7) × 0.11	=	_____
+ _____ m (Ø 19.1) × 0.26	=	_____
Total top-up volume	=	_____

Refrigerant pipes for Belaria® VRF (33)

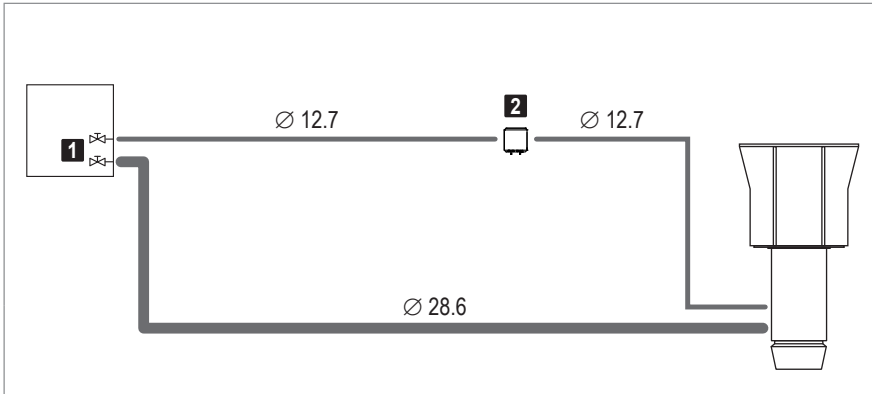

- 1** Connections on the heat pump
 - Liquid line Ø 15.9 mm
 - Gas line Ø 28.6 mm
- 2** Expansion valve and combi box VRF 02 (supplied loose for installation on-site on the indoor climate unit)

Fig. D12: Refrigerant pipes for Belaria® VRF (33) (pipe diameter in mm)

Refrigerant pipes for Belaria® VRF (40)

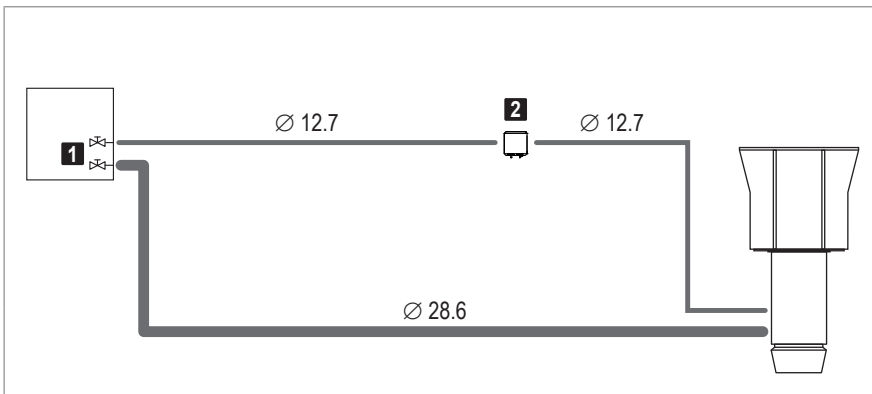

- 1** Connections on the heat pump
 - Liquid line Ø 15.9 mm
 - Gas line Ø 31.8 mm
- 2** Expansion valve and combi box VRF 03 (supplied loose for installation on-site on the indoor climate unit)

Fig. D13: Refrigerant pipes for Belaria® VRF (40) (pipe diameter in mm)

Refrigerant pipes for Belaria® VRF (67)

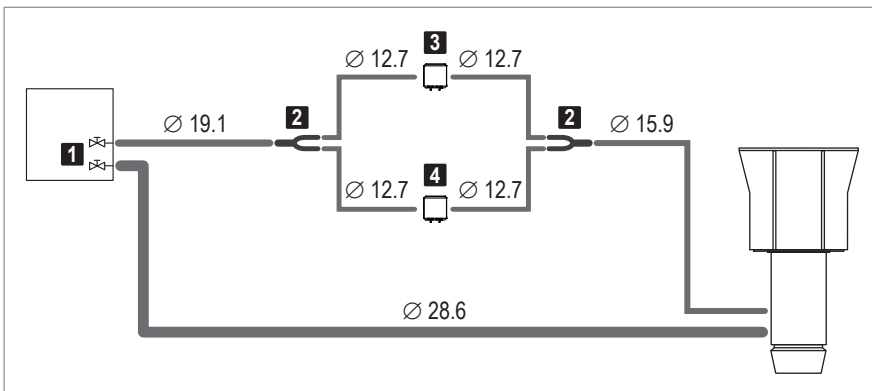

- 1** Connections on the heat pump
 - Liquid line Ø 19.1 mm
 - Gas line Ø 31.8 mm
- 2** Branching kit, supplied loose
- 3** Expansion valve and combi box VRF 02 (supplied loose for installation on-site on the indoor climate unit)
- 4** Expansion valve and combi box VRF 03 (supplied loose for installation on-site on the indoor climate unit)

Fig. D14: Refrigerant pipes for Belaria® VRF (67) (pipe diameter in mm)

3 Hydraulic installation

3.1 Condensate connection

RoofVent® unit

Condensate arising in cooling units must be removed via a condensate-proof line.

- Install and insulate the supplied trap on the condensate connection of the unit.
- Dimension the slope and cross-section of the condensate line so that no condensate backflow takes place.
- Make sure that the condensate produced is drained in compliance with local regulations.
- Route the condensate line from the pump directly upwards.



Notice

Use the 'Condensate pump' option for quick and easy hydraulic installation.

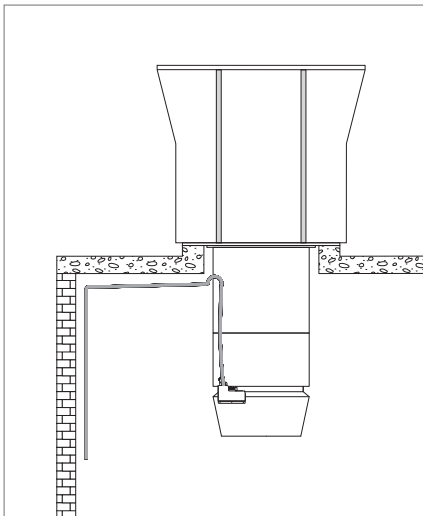

Fig. D15: Condensate line

Heat pump

- Make sure that the heat pump is not damaged by pooling water or ice formation:
 - Make sure that water is free to drain through the bottom plate of the heat pump.

4 Electrical installation

- The electrical installation must only be carried out by a qualified electrician.
- Observe the relevant regulations (e.g. EN 60204-1).
- Choose the dimensions of the cable cross sections in line with the applicable regulations.
- Route signal and bus lines separately from mains cables.
- Make sure the lightning protection system for the units or for the entire building is planned and carried out by professionals.
- Provide overload protection equipment on site in the mains connection line of the zone control panel.
- Carry out the electrical installation according to the wiring diagram:
 - Power supply for RoofVent® RP
 - Power supply for Belaria® heat pump with main switch in view of the heat pump
 - Zone bus based on system layout
 - Signal lines
- In the RoofVent® RP unit, connect the connection box in the below-roof unit to the control block in the roof unit.
- Connect the electrical components of the below-roof unit to the connection box.
- Connect the electrical components of the heat pump system.
- Connect the optional components to the connection box.

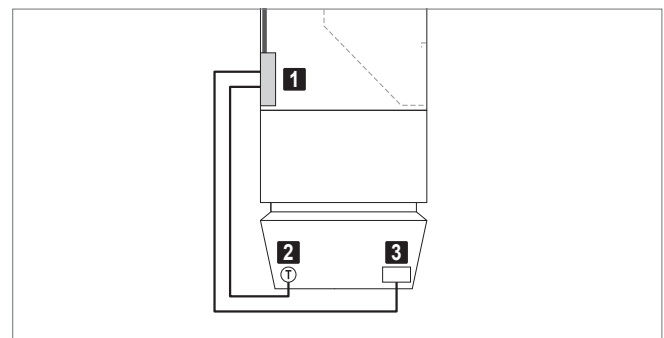

- 1 Connection box
- 2 Supply air temperature sensor
- 3 Actuator Air-Injector

Fig. D16: On-site electrical connection of the Air-Injector and supply air temperature sensor

4.1 Electrical installation for RoofVent® RP-6

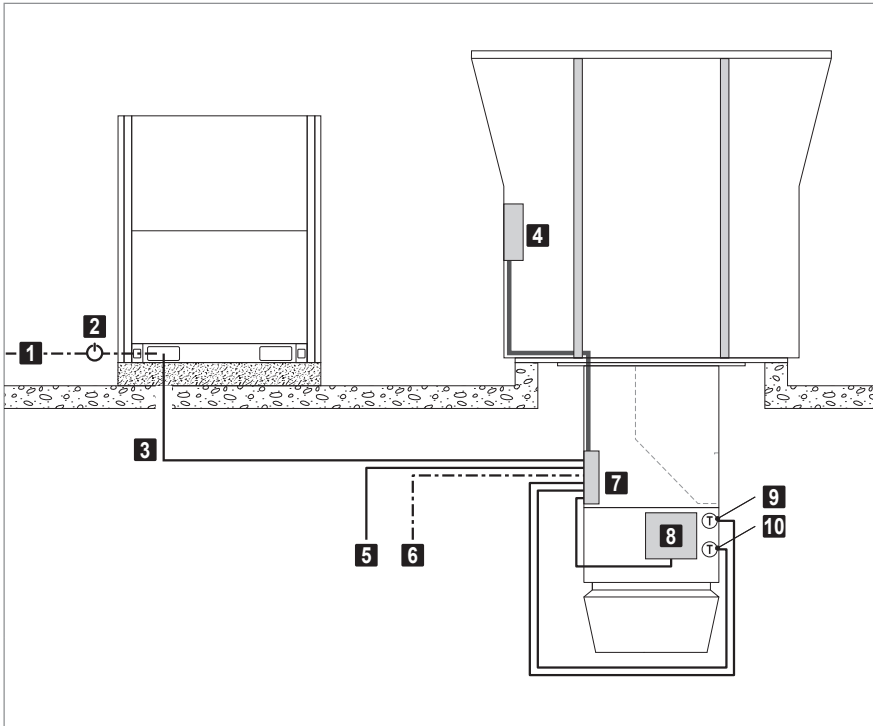

- 1 Power supply heat pump
- 2 Heat pump main switch (on-site)
- 3 Communication RoofVent®
- 4 Control block with conversion board
- 5 Zone bus
- 6 Power supply RoofVent®
- 7 Connection box
- 8 Combi box VRF (expansion valve)
- 9 Gas temperature sensor (T2B, supplied loose)
- 10 Liquid temperature sensor (T2A + T2)

Fig. D17: Electrical connection of the heat pump system for RoofVent® RP-6

4.2 Electrical installation for RoofVent® RP-9

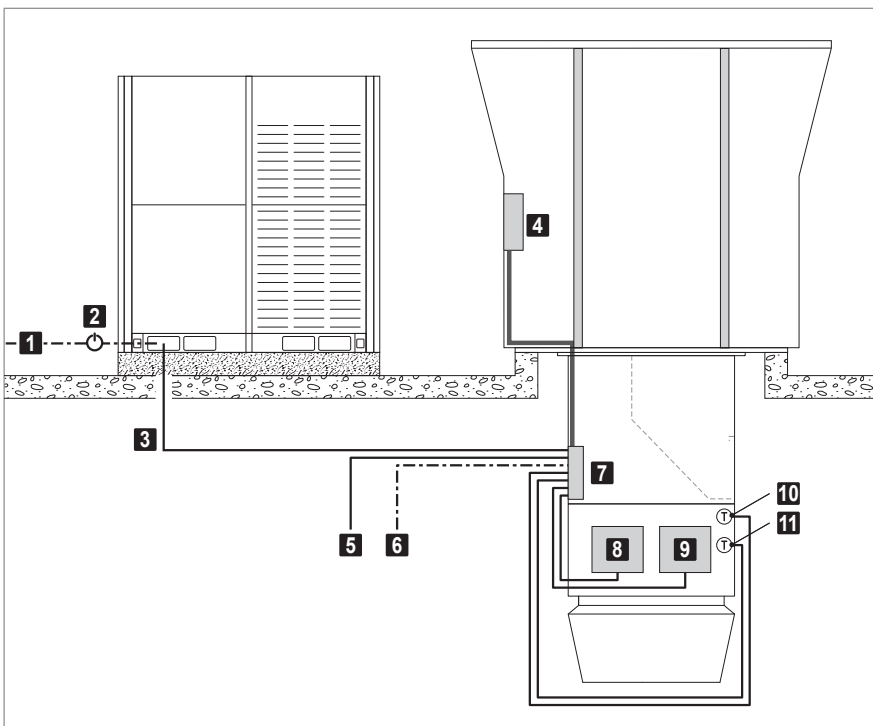

- 1 Power supply heat pump
- 2 Heat pump main switch (on-site)
- 3 Communication RoofVent®
- 4 Control block with conversion boards
- 5 Zone bus
- 6 Power supply RoofVent®
- 7 Connection box
- 8 Combi box VRF 02 – client (expansion valve)
- 9 Combi box VRF 03 – server (expansion valve)
- 10 Gas temperature sensor (T2B, supplied loose)
- 11 Liquid temperature sensor (T2A + T2)

Fig. D18: Electrical connection of the heat pump system for RoofVent® RP-9

Component	Designation	Voltage	Cable	Comments	Start	Target	
TopTronic® C System control	Power supply	3 × 400 VAC	NYM-J 5 × ... mm ²		On-site	Zone control panel	
		1 × 230 VAC	NYM-J 3 × ... mm ²		On-site	Zone control panel	
Zone control panel	Zone bus		J-Y(ST)Y 2 × 2 × 0.8 mm	max. 500 m length	Zone control panel	Hoval units	
	System bus		Ethernet ≥ CAT 5	For connecting several zone control panels	Zone control panel	Further zone control panel	
	Integration into the building management system		Ethernet ≥ CAT 5		BACnet, Modbus IP	Zone control panel	On-site (BMS)
			J-Y(ST)Y 2 × 2 × 0.8 mm		Modbus RTU	Zone control panel	On-site (BMS)
	Room temperature sensor		J-Y(ST)Y 2 × 2 × 0.8 mm	max. 250 m	Zone control panel	Sensors	
	Additional room temperature sensors		J-Y(ST)Y 2 × 2 × 0.8 mm	max. 250 m	Zone control panel	Sensors	
	Combination sensor room air quality, temperature and humidity		J-Y(ST)Y 4 × 2 × 0.8 mm	max. 250 m	Zone control panel	Sensors	
	Fresh air temperature sensor		J-Y(ST)Y 2 × 2 × 0.8 mm	max. 250 m	Zone control panel	Sensors	
	Combination sensor fresh air temperature and humidity		J-Y(ST)Y 2 × 2 × 0.8 mm	max. 250 m	Zone control panel	Sensors	
	Collective alarm	Volt-free max. 230 VAC max. 24 VDC	NYM-O 2 × 1.5 mm ²	max. 3 A max. 2 A		Zone control panel	On-site
	Power supply for units		3 × 400 VAC	NYM-J 5 × 1.5 mm ² (min.)	RoofVent® size 6	Zone control panel or on-site	Hoval units
			3 × 400 VAC	NYM-J 5 × 4.0 mm ² (min.)	RoofVent® size 9		
			3 × 400 VAC	NYM-J 5 × 1.5 mm ² (min.)	TopVent®		
	Power supply for heat pump		3 × 400 VAC	NYM-J 5 × 4.0 mm ² (min.)	Belaria® VRF (33) (for 100 m length)	Zone control panel or on-site	Hoval heat pump
			3 × 400 VAC	NYM-J 5 × 6.0 mm ² (min.)	Belaria® VRF (40) (for 100 m length)		
			3 × 400 VAC	NYM-J 5 × 10.0 mm ² (min.)	Belaria® VRF (67) (for 100 m length)		
	System operator terminal (if external)		24 VDC	NYM-J 3 × 1.5 mm ²	Power supply 0.42 A	Zone control panel	System operator terminal
				Ethernet ≥ CAT 5	Communication	Zone control panel	System operator terminal
	Zone operator terminal (if external)	24 VAC	J-Y(ST)Y 4 × 2 × 0.8 mm		Power supply, 1 A fusing, max. 250 m length	Zone control panel	Zone operator terminal
	External sensor values	0-10 VDC	J-Y(ST)Y 2 × 2 × 0.8 mm			On-site	Zone control panel
External set values	0-10 VDC	J-Y(ST)Y 2 × 2 × 0.8 mm			On-site	Zone control panel	
Load shedding input	24 VAC	NYM-O 2 × 1.5 mm ²		max. 1 A	On-site	Zone control panel	
Operating selector switch on terminal (analogue)	0-10 VDC	J-Y(ST)Y 2 × 2 × 0.8 mm			On-site (switch)	Zone control panel	
Operating selector switch on terminal (digital)	0-10 VDC	J-Y(ST)Y 6 × 2 × 0.8 mm			On-site (switch)	Zone control panel	
Operating selector button on terminal	24 VAC	J-Y(ST)Y 6 × 2 × 0.8 mm			On-site (button)	Zone control panel	
Forced off	24 VAC	NYM-O 2 × 1.5 mm ²		max. 1 A	On-site	Zone control panel	
Heating/cooling changeover	24 VAC	NYM-O 2 × 1.5 mm ²		Signal external enabling/setting max. 1 A	On-site	Zone control panel	

Component	Designation	Voltage	Cable	Comments	Start	Target
RoofVent® unit	Power supply	3 × 400 VAC	NYM-J 5 × 1.5 mm ² (min.)	RoofVent® size 6	Zone control panel or on-site	RoofVent® unit
		3 × 400 VAC	NYM-J 5 × 4.0 mm ² (min.)	RoofVent® size 9		
	Zone bus		J-Y(ST)Y 2 × 2 × 0.8 mm	max. 500 m length	Zone control panel	RoofVent® unit
	Forced off	24 VAC	NYM-O 2 × 1.5 mm ²	max. 1 A	On-site	RoofVent® unit
Belaria® VRF heat pump	Power supply	3 × 400 VAC	NYM-J 5 × 4.0 mm ² (min.)	Belaria® VRF (33) (for 100 m length)	Zone control panel or on-site	Hoval heat pump
		3 × 400 VAC	NYM-J 5 × 6.0 mm ² (min.)	Belaria® VRF (40) (for 100 m length)		
		3 × 400 VAC	NYM-J 5 × 10.0 mm ² (min.)	Belaria® VRF (67) (for 100 m length)		
	Communication RoofVent®		J-Y(ST)Y 2 × 2 × 0.8 mm		RoofVent® unit	Hoval heat pump

Table D9: Cable list for on-site connections



System design

1 Design example. 56

2 Maintenance schedule 58

3 Checklist for project discussions 59

1 Design example



Notice

Use the 'HK-Select' program to design Hoval Indoor Climate Systems. You can download it free of charge on the Internet.

Design data	Example
<ul style="list-style-type: none"> Hall geometry (L × W × H) Required fresh air flow rate Internal heat gains (machines, lighting, etc.) Heating and cooling with decentralised heat pump Optimisation of the ventilation quality (no limitation on the number of units) 	52 × 42 × 9 m 32000 m ³ /h 23 kW → Unit type RP → Unit size 6
Design conditions heating: <ul style="list-style-type: none"> Fresh air temperature Room temperature Extract air conditions Fabric heat losses 	- 8 °C 20 °C 22 °C / 40 %rh 93 kW
Design conditions cooling: <ul style="list-style-type: none"> Fresh air temperature Room temperature Extract air temperature Transmission sensible gains 	32 °C / 40 %rh 26 °C 28 °C 47 kW
<p>Number of units</p> <ul style="list-style-type: none"> Calculate the required number of units: $n = \text{Fresh air flow rate} / \text{nominal air flow rate}$	$n = 32000 / 5500 = 5.8$ → 6 units (size 6)
<p>Type of heating coil</p> <ul style="list-style-type: none"> Calculate the required heat output for coverage of fabric heat losses per unit: $Q_{H_req} = (\text{fabric heat losses} - \text{internal heat loads}) / n$ <ul style="list-style-type: none"> Use the 'Hoval HK-Select' selection program to calculate the heat output for coverage of fabric heat losses under the given design conditions and select the suitable coil type. <ul style="list-style-type: none"> To ensure that the plate heat exchanger cannot freeze, calculate the output data in the 'with icing protection' mode. 	$(93 - 23) / 6 = 11.7 \text{ kW per unit}$ RP-6-J: 12.3 kW RP-6-L: 18.7 kW → Heating/cooling coil type J
<p>Type of cooling coil</p> <ul style="list-style-type: none"> Calculate the required cooling capacity for coverage of transmission sensible gains per unit: $Q_{C_req} = (\text{transmission sensible gains} + \text{internal heat loads}) / n$ <ul style="list-style-type: none"> Use the 'Hoval HK-Select' selection program to calculate the cooling capacity for coverage of transmission sensible gains under the given design conditions and select the suitable coil type. 	$(47 + 23) / 6 = 11.7 \text{ kW per unit}$ RP-6-J: 16.5 kW RP-6-L: 20.7 kW → Heating/cooling coil type J

Checks	
<ul style="list-style-type: none"> Effective air flow rate <p>$V_{\text{eff}} = \text{Nominal air flow rate} \times n$</p>	$5500 \times 6 = 33000 \text{ m}^3/\text{h}$ $33000 \text{ m}^3/\text{h} > 32000 \text{ m}^3/\text{h}$ → OK
<ul style="list-style-type: none"> Effective heat output <p>$Q_{\text{H_effective}} = \text{Output for coverage of fabric heat losses} \times n$</p>	$12.3 \times 6 = 73.8 \text{ kW}$ $73.8 \text{ kW} > (93 - 23) \text{ kW}$ → OK
<ul style="list-style-type: none"> Mounting height <p>Calculate the actual mounting height (= distance between the floor and the bottom edge of the unit) and compare with the minimum and maximum mounting height.</p> <p>$Y = \text{Hall height} - \text{length of below-roof unit}$</p>	$9000 - 2050 = 6950 \text{ mm}$ $Y_{\text{min}} = 4.0 \text{ m} < 6.95 \text{ m}$ → OK $Y_{\text{max}} = 20.0 \text{ m} > 6.95 \text{ m}$ → OK
<ul style="list-style-type: none"> Effective cooling capacity <p>$Q_{\text{c_effective}} = \text{Output for coverage of transmission sensible gains} \times n$</p>	$16.5 \times 6 = 99.0 \text{ kW}$ $99.0 \text{ kW} > (47 + 23) \text{ kW}$ → OK
<ul style="list-style-type: none"> Floor area covered <p>Compare the floor area covered with the base area of the hall (L × W).</p> <p>$A = \text{Floor area covered} \times n$</p>	$480 \times 6 = 2880 \text{ m}^2$ $52 \times 42 = 2184 \text{ m}^2$ $2880 \text{ m}^2 > 2184 \text{ m}^2$ → OK
<ul style="list-style-type: none"> Minimum and maximum clearances <p>Determine the positioning of the units according to the number of units and the base area of the hall; check the minimum and maximum clearances.</p>	$n = 6 = 3 \times 2$ Unit clearance in length: $X = 52 / 3 = 17.3 \text{ m}$ $X_{\text{max}} = 22.0 \geq 17.3 \text{ m}$ $X_{\text{min}} = 11.0 \leq 17.3 \text{ m}$ → OK Unit clearance in width: $X = 42 / 2 = 21.0 \text{ m}$ $X_{\text{max}} = 22.0 \geq 21.0 \text{ m}$ $X_{\text{min}} = 11.0 \leq 21.0 \text{ m}$ → OK

2 Maintenance schedule

Activity	Interval
Renew air filter	When the filter alarm is displayed, at least annually
Comprehensively checking function; cleaning and possibly repairing the RoofVent® unit and the Belaria® VRF heat pump	Annually by Hoval customer service

Table E1: Maintenance schedule

Project

Project No.

Date

Name

Function

Address

Tel.

Fax

E-mail

Information about the hall

Application

Type

Insulation

Length

Width

Height

Is the roof strong enough?

yes no

Are there window areas?

yes no

Percentage?

Is there a crane?

yes no

Height?

Is there enough space for installation and servicing?

yes no

Are there any voluminous installations or machines?

yes no

Are pollutants present?

yes no

Which?

– If yes, are they heavier than air?

yes no

Is oil contained in the extract air?

yes no

Is dust present?

yes no

Dust level?

Is there high humidity?

yes no

How much?

Is the air volume balanced?

yes no

Are local machine extractions required?

yes no

Are any conditions imposed by public authorities?

yes no

Which?

Are sound level requirements to be fulfilled?

yes no

Which?

Design data

Fresh air flow rate?	<input type="text"/>	m ³ /h
Fresh air / hall area	<input type="text"/>	m ³ /h per m ²
Air change rate	<input type="text"/>	
Internal heat gains (machines, ...)	<input type="text"/>	kW
Heating and cooling	<input type="text"/>	
Unit size	<input type="text"/>	
Control zones	<input type="text"/>	

Design conditions heating

■ Highest outside temperature and humidity	<input type="text"/>	°C	<input type="text"/>	%
■ Room temperature	<input type="text"/>	°C		
■ Extract air temperature and humidity	<input type="text"/>	°C	<input type="text"/>	%
■ Fabric heat losses	<input type="text"/>	kW		

Design conditions cooling

■ Highest outside temperature and humidity	<input type="text"/>	°C	<input type="text"/>	%
■ Room temperature	<input type="text"/>	°C		
■ Extract air temperature and humidity	<input type="text"/>	°C	<input type="text"/>	%
■ Transmission sensible gains	<input type="text"/>	kW		

Further information

Hoval quality.
You can count on us.

As a specialist in heating and climate technology, Hoval is your experienced partner for system solutions. For example, you can heat water with the sun's energy and your rooms with oil, gas, wood or a heat pump. Hoval ties together the various technologies and also integrates room ventilation into the system. So you can save energy while looking after the environment and your costs – and still enjoy the same level of comfort.

Hoval is one of the leading international companies for indoor climate solutions. More than 75 years of experience continuously motivate us to design innovative system solutions. We manufacture complete systems for heating, cooling and ventilation to more than 50 countries.

We take our responsibility for the environment seriously. Energy efficiency is at the heart of the heating and ventilation systems we design and develop.

Responsibility for energy and environment

United Kingdom

Hoval Ltd.
Northgate, Newark
Nottinghamshire
NG24 1JN
hoval.co.uk

Your Hoval partner